

Flexural buckling of aluminium columns - research review

Čudina, Ivan; Skejić, Davor.

Source / Izvornik: **7. simpozij doktorskog studija građevinarstva 2021. : zbornik radova, 2021, 21 - 33**

Conference paper / Rad u zborniku

Publication status / Verzija rada: **Published version / Objavljena verzija rada (izdavačev PDF)**

<https://doi.org/10.5592/CO/PhDSym.2021.02>

Permanent link / Trajna poveznica: <https://um.nsk.hr/um:nbn:hr:237:517817>

Rights / Prava: [In copyright](#) / [Zaštićeno autorskim pravom.](#)

Download date / Datum preuzimanja: **2025-01-01**

Repository / Repozitorij:

[Repository of the Faculty of Civil Engineering,
University of Zagreb](#)



Flexural buckling of aluminium columns - Research review

Ivan Čudina¹, Prof. Davor Skejić²

¹ University of Zagreb, Faculty of Civil Engineering, Department for Structures, ivan.cudina@grad.unizg.hr

² University of Zagreb, Faculty of Civil Engineering, Department for Structures, davor.skejic@grad.unizg.hr

Abstract

The use of aluminium lags behind other materials partially due to a lack of design standards in the past. That problem was solved with the development of new standards for the design of aluminium structures. The aluminium column design procedure implies flexural buckling verification, and Eurocode 9 provides design procedures for extruded and welded columns. Due to a lack of recent studies, the design procedure for longitudinally welded columns was based on experimental research conducted more than 40 years ago. An experimental study and detailed numerical analysis of longitudinally welded aluminium columns is required to assess the accuracy of the current design procedure.

Key words: aluminium, flexural buckling, welded columns, longitudinal weld, design

Izvijanje uz savijanje aluminijskih stupova – pregled dosadašnjih istraživanja

Sažetak

Aluminij po svojoj primjeni zaostaje za drugim materijalima jednostavno zato što u prošlosti nisu postojale norme za projektiranje. Taj problem riješen je s razvojem novih normi za projektiranje aluminijskih konstrukcija. Postupak projektiranja aluminijskih stupova podrazumijeva provjeru stabilnosti na izvijanje uz savijanje, a u tom smislu se u Eurokodu 9 prikazuju postupci za projektiranje ekstrudiranih i zavarenih stupova. Zbog nedostatka novijih studija, postupak projektiranja uzdužno zavarenih stupova temeljio se na eksperimentalnim istraživanjima koja su provedena prije više od četiri desetljeća. Potrebna je eksperimentalna studija i detaljna numerička analiza uzdužno zavarenih aluminijskih stupova kako bi se ocijenila vjerodostojnost sadašnjeg postupka projektiranja.

Cljučne riječi: aluminij, izvijanje uz savijanje, zavareni stupovi, uzdužni zavar, projektiranje

1 Introduction

Although aluminium is the third most abundant element in the Earth's crust after oxygen and silicon, it was not discovered in its elemental state until 1825 [1]. Shortly thereafter, mass production of aluminium began following invention of the Hall–Héroult process in 1886 [2]. Since aluminium in its elemental state is not suitable for application in civil engineering, it is used in the form of alloys [2]. Based on the primary alloying element, aluminium alloys are divided into eight different series [1] and may have different types of treatment (temper). Main advantages of aluminium as a structural material are the lightness, corrosion resistance, and functionality of the structural form [3, 4]. Moreover, due to formation of a thin oxide layer on the surface, aluminium is corrosion resistant and suitable for use in aggressive environments [1, 3]. Unlike steel products, which are mainly produced by rolling, aluminium products are mainly extruded, which allows an unlimited choice of cross-sectional shapes that cannot be achieved with more conventional structural materials [5], Figure 1. In cases where extruded members are inadequate, aluminium sections of larger dimensions can be formed by welding.

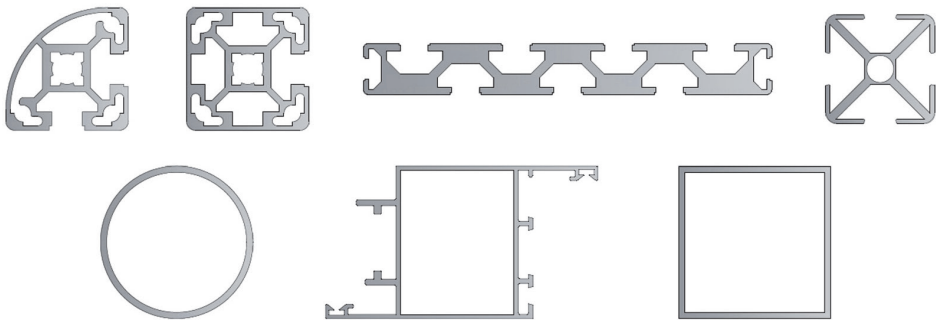

Figure 1. Extruded aluminium cross-sectional shapes

Another advantage of aluminium as a structural material is that the melting process does not affect its properties, i.e., it can be recycled indefinitely [6]. Moreover, the production of recycled aluminium (secondary production) consumes 20 times less energy than the production of new aluminium (primary production), which earns it the title of “green metal” [5, 6]. However, it should be noted that the primary production of aluminium consumes a considerable amount of electrical energy, which makes it relatively expensive [6]. Even with the advances in the production process of aluminium alloys, which have reduced the energy demand by more than 75 % since 1995 [5], aluminium is still more expensive than steel as a structural material. The first use of aluminium as a construction element was recorded in 1898, when aluminium plates were used to cover the dome of the St. Jacob's Church in Rome, and

they have remained undamaged to this day [2]. Since then, the use of aluminium in construction industry has been gradually increasing and currently occupies around 25 % of the total aluminium production worldwide [5]. Some examples of structural aluminium application in façade systems are shown in Figure 2. For several reasons, such as the high price of primary aluminium production, the use of aluminium in construction today lags significantly behind conventional materials such as steel and reinforced concrete. Another reason is the insufficient or even non-existent standards and recommendations for the design of aluminium structures in the past [1]. Although aluminium alloys and structural steel share many common properties, the design methods developed for steel cannot be applied to aluminium members [6]. Therefore, design manuals for aluminium were developed relatively late. The Aluminum Association (AA) published the first international manual *Specification for Aluminum Structures* in 1967.



Figure 2. Structural application of aluminium façade systems: a) Cable car Sljeme in Zagreb; b) Urbanest building in London

The development of European standards for the design of aluminium structures began in 1978 with the first edition of the ECCS committee recommendations [1]. However, the normative background established then did not offer the same level of elaboration in the design approach as that provided to standards for more commonly used materials [6]. Hence, the usage of aluminium as a structural material was still inhibited with an inadequate normative background. Structural behaviour of both extruded and welded aluminium members has been widely researched over the last few decades [7] and the conclusions reached provided a solid foundation for modern standardization [1]. Since then, the development of standards has progressed significantly and limitations caused by the insufficiency and absence of standards, have been surpassed. The version of Eurocode 9 published in 2007 is presently used for the design of aluminium structures in Europe. Still, the development of standards for the design of structures is an ever ongoing process, and Eurocodes are no exception. The new generation of Eurocodes is currently in the

final phase of development, and all standards, including EN 1999-1-1 [8], have been subjected to critical review and alterations [9]. Inconsistencies in the stability verification procedure were found in [8], primarily for longitudinally welded columns. Non-welded members have also been subjected to critical review and revision [9]. Accordingly, prEN 1999-1-1 [10] brings significant changes in the stability verification procedure for both welded and non-welded aluminium members under compression. This paper brings an insight into the experimental and numerical background of modifications made in the stability verification procedure for aluminium members under compression. Furthermore, this paper points out inadequacies in the stability verification procedure for the longitudinally welded members in [10], namely the limited experimental background on which it was based.

2 Stability of aluminium members under compression

2.1 General

Due to low modulus of elasticity and material non-linearity, aluminium alloys are susceptible to stability loss, especially if members with slender cross-sections are considered [11]. The buckling resistance of aluminium members depends on the initial bow (geometrical imperfection), stress-strain relationship, and residual stresses (structural imperfection) [12]. When referring to the buckling of aluminium members, one must consider extruded and welded members separately. Extruded aluminium sections show small to negligible residual stresses, but the stress-strain relationship is distinctly non-linear [13]. In addition, as the extrusion process allows for greater functionality of structural shape, aluminium sections are very often produced for a specific purpose resulting in the complexity of cross-sectional shapes [2]. Extruded members are subjected to various buckling interactions that are identified in cold-formed steel members as well. On the other hand, welding causes significant reduction of mechanical properties in aluminium [2] as well as introduction of residual stresses in cross-sections of members. The size and position of the heat-affected zone (HAZ) affect the buckling resistance of longitudinally welded columns [12]. Hence, a realistic determination of buckling resistance of both longitudinally welded and extruded members can be regarded as a complex endeavour. The first and crucial step in stability verification of aluminium and steel columns is the selection of the buckling curve. The most important factor affecting buckling resistance of steel columns are residual stresses, which mainly depend on the cross-sectional shape [13]. Accordingly, the selection of the buckling curve in EC3 [14] is determined by the cross-sectional shape of the member. The residual stresses of extruded aluminium members are extremely small, but the stress-strain relationship is distinctly non-linear [13]. Therefore, EC9 [8] defines the choice of

buckling curve for aluminium compression members depending on the choice of aluminium alloy and temper. Currently, EC9 [8] defines the buckling curves A and B for members subjected to flexural buckling.

2.2 Flexural buckling of extruded aluminium columns

The behaviour of extruded aluminium columns under compression has been well studied over the years, both experimentally and numerically. One of the earliest studies on the stability of aluminium columns was performed by Osgood and Holt and published in 1938 as NACA Report No. 656 [15]. Since then, numerous authors have conducted and published research on the stability of aluminium columns under compression. It can therefore be stated that the current standards for the buckling design of extruded aluminium columns are based on an extensive experimental and numerical basis, including the current version of the European standard for the design of aluminium structures, Eurocode 9. Since its publication in 2007, further research on aluminium columns has been carried out and new knowledge has been gained.

Zhu and Young [16-18] conducted a series of laboratory tests on extruded aluminium columns of circular, rectangular, and square hollow section. In total, 70 fixed-ended aluminium columns with lengths between 300 - 3000 mm, both unwelded and with transverse welds, were tested. Also, the authors conducted parametric nonlinear numerical analysis, including 248 models, and the results showed good correspondence with laboratory tests. The results of laboratory tests and numerical analyses were compared to Australian/New Zealand, American, and European standards for the design of aluminium columns. It was concluded that extruded hollow columns with transverse welds reached between 54 - 77 % of buckling resistance compared to equivalent unwelded columns [16-18]. Furthermore, the authors stated that the standards considered were on the conservative side when predicting buckling resistance of aluminium columns. However, Australian/New Zealand and American standards, but not European ones, were nonconservative in a few cases for hollow aluminium columns with transverse welds. Finally, a new design method based on the direct strength method was proposed for extruded hollow aluminium columns under compression. The current direct strength method compared well with experimental and numerical results alike, and is suitable for the design of extruded rectangular, square, and circular hollow sections without welds. The authors stated that with slight modifications the current direct strength method achieved a reliability index closer to the target value compared with the current method.

Adeoti et al. [19] proposed a buckling curve for flexural buckling of extruded aluminium columns based on laboratory testing and nonlinear numerical analyses. In total, 30 pin-ended extruded aluminium column samples made of AW 6082-T6 alloy were tested under compression, 15 with hollow rectangular cross-section, and

15 with H cross-section. Numerical models were calibrated on the laboratory test results, and numerical parametric analysis was conducted. The proposed buckling curve was compared to buckling curves given in the American, European, and Chinese design codes for aluminium and steel structures. It was concluded that the buckling curve proposed in the research coincides well with buckling curves given in European and Chinese codes. However, the proposed curve gives slightly higher buckling resistances compared to those given in the design codes [19].

Wang et al. [20] conducted a series of laboratory tests on circular tube columns made of aluminium alloy AW 6082-T6. The first series of tests included nine fixed-ended stub columns subjected to axial force to obtain stress-strain curves. The second series of tests included 15 pin-ended circular tube columns with various slenderness ratios, subjected to axial force to obtain buckling strengths and failure modes. Geometrical imperfections of all 15 columns were also measured. Experimental buckling strengths were compared with the buckling strengths obtained according to several aluminium design codes. The authors stated that the American Aluminium Design Manual [21] gives conservative results for circular tube columns, especially for columns with low slenderness [20]. The Australian/New Zealand Standard 1664 [22] gave conservative results for columns with low slenderness but was unsafe for columns with high slenderness [20]. Finally, the Eurocode 9 [8] gave generally conservative results for circular tube columns, regardless of slenderness ratio [20]. Wang et al. [23] investigated resistance of the extruded aluminium I section columns with fixed-pinned end conditions subjected to compression. Laboratory tests included 11 aluminium columns made of AW 6061-T6 and AW 6063-T5 alloys as well as coupon tests to determine mechanical properties. Local and global geometrical imperfections were also measured. The numerical model was developed and calibrated on the laboratory test results to conduct nonlinear parametric analysis. Finally, the obtained buckling resistances were used to assess European, Chinese, American, and Australian/New Zealand design codes. The research showed that 9 out of 11 laboratory samples failed by the interaction of local and global failure modes [23]. Also, the authors stated that the buckling resistances obtained based on the observed standards were conservative, especially for the alloys with larger strain hardening capacity. European and Chinese design standards for aluminium structures underestimate the post-buckling capacity of extruded aluminium columns by 30 % [23]. On the other hand, Australian/New Zealand design standards revealed better correspondence. It was also observed that the buckling length factor for fixed-pinned end conditions was between 0,732 - 0,850, which is higher than the theoretical value of 0,7 [23].

Wang et al. [24] also investigated buckling resistance of aluminium alloy column members of large cross-section. The experimental investigation involved 7 aluminium members subjected to axial compression, four with I section and seven with

rectangular hollow section. All columns failed in flexural buckling mode. Parametric nonlinear numerical analysis including 180 specimens was also conducted to evaluate reliability levels of the current design standards. It was concluded that stability resistances obtained by Eurocode 9 [8] and Chinese code GB 50429 [25] are conservative. On the other hand, American Aluminium Design Manual [21] slightly overestimated the stability resistance of aluminium alloy column members [24]. Based on the design method given in Eurocode 9 [8], the authors proposed a new design method that predicts relatively well the buckling resistance of aluminium columns, regardless of the cross-sectional dimensions.

Table 1. Overview of experimental research related to stability of extruded aluminium columns

Paper	Cross-sectional shape	Alloy and temper	Number of samples		Additional notes
Zhu, J. (2006) [16] Zhu and Young (2006) [17] Zhu and Young (2006) [18]	Circular hollow Rectangular hollow Square hollow	AW 6063-T5 AW 6061-T6	70	29 circular	Initial geometrical imperfections were also measured. Non-welded and welded mechanical properties measured (assessment of welding induced properties reduction). Modified direct strength method proposed for aluminium columns with transverse welds.
		41 rectangular and square			
Adeoti et al. (2015) [19]	Rectangular hollow H section	AW 6082-T6	30	15 rectangular	Mechanical properties measured with tensile coupon tests. Geometrical imperfection measured ($L/7500$ taken in numerical analysis; L – length of the specimen).
				15 H section	
Wang et al. (2015) [20]	Circular hollow	AW6082-T6	15		The obtained stress–strain relationships showed good correspondence with the Ramberg–Osgood expression.
Wang et al. (2017) [23]	I section	AW 6061-T6 AW 6063-T5	11		Strengths predicted by considered design codes were less conservative for 6061-T6 alloy specimens compared to 6063-T5 alloy specimens, due to a more pronounced strain hardening capacity of the latter.
Wang et al. (2018) [24]	Rectangular hollow I section	AW 6061-T6	7	4 I section	The accuracy of the considered design codes does not change with the variation of cross-sectional dimensions, which indicated that current design codes are applicable for large-section columns.
				3 rectangular	

The development of the new generation of Eurocodes is currently in its final phase. All the standards, including EN 1999-1-1 [8], were subjected to critical review and modifications aiming to provide more uniform reliability of structures. Based on the above studies [16-24], the design procedure for stability verification of both welded and non-welded aluminium columns, was revised [9]. The introduction of a new buckling class C and alterations in the allocation of existing alloys and tempers to buckling classes can be considered as the most significant changes [9]. The allocation is now based on the exponent n_p which is the n value in the Ramberg-Osgood expression for the plastic analysis [8, 9]. Also, minor improvements have been made to buckling curves A and B [9].

2.3 Flexural buckling of longitudinally welded aluminium columns

Unlike extruded columns, the stability of longitudinally welded aluminium columns has not been thoroughly studied. The earliest report on longitudinally welded aluminium columns was published by Hill, Brungraber, and Clark in 1962 [26]. However, the studies presented concerned mainly straight aluminium columns made of narrow rectangular plates, and some of the stated conclusions were questionable [27]. No further studies were conducted until the ECCS committee T2 carried out extensive research on longitudinally welded AW 6082-T6 alloy columns [27]. Members with three different types of cross-sections were tested, Figure 3, and the results were published by Frey [28] in 1977, and by Faella and Mazzolani [29] in 1978 [7]. Furthermore, Gatto, Mazzolani, and Morri [16-18] measured residual stresses for a range of welded structural shapes [7], Figure 3. The above research gave a foundation for the development of the stability verification procedure for longitudinally welded aluminium columns, which was published in the first edition of the ECCS Recommendations for the design of aluminium structures [30] in 1978. The stability verification procedure for longitudinally welded members given in the current version of EC9 [8] is more advanced compared to the procedure given in [30], but is mostly based on the same experimental research. Since EC9 was published in 2007, almost no experimental research has been conducted on the stability of longitudinally welded aluminium columns under compression. Experimental research on longitudinally welded columns was recently conducted by Wu and Zhang [31]. The stated authors presented experimental research on 20 longitudinally welded AW 6061-T6 aluminium alloy I-section columns under axial compression. Column specimens of various lengths were tested, and the results were compared with design strengths calculated according to the Eurocode and the China Code for aluminium structures. The tensile coupon test and hardness test were also performed to determine the width of the heat affected zone and reduced strength zone (RSZ). It was concluded that with slight modifications in the procedure, the China Code and the European Code were in good agreement with experimental results for type T section, but conservative for type P.

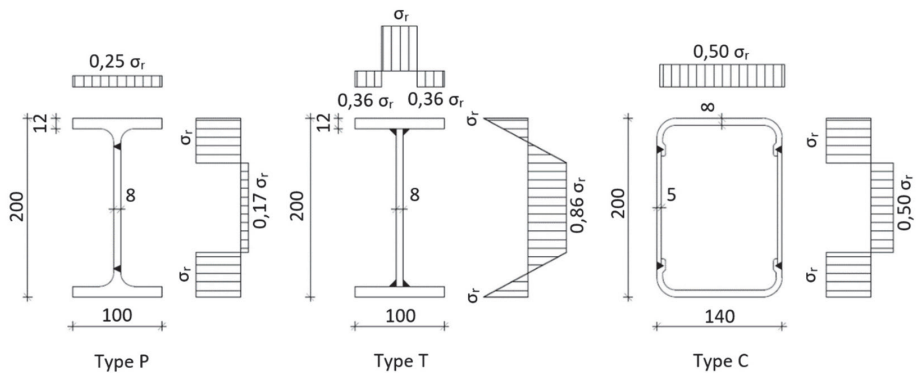

Figure 3. Cross-section shapes of longitudinally welded aluminium specimens with the corresponding residual stress distribution models (σ_r denotes the maximum residual stress value related to mechanical properties of the alloy) [7]



Figure 4. Longitudinally welded aluminium specimens: a) Type T cross-section; b) Type P cross-section [31]

The design procedure for longitudinally welded aluminium members was revised and improved in the scope of the current revision of Eurocodes [9]. Three separate buckling classes (curves) for longitudinally welded elements were introduced with regard to extruded columns. The authors stated that, for alloys and tempers assigned to buckling classes A and B, the effect of the strength reduction in HAZ is more pronounced compared to residual stresses. In the case of buckling class C, the column buckling behaviour is influenced both by residual stresses and cross-section type. Due to the lack of recent experimental background on longitudinally welded columns, Misiek et al. [12] performed revision of the procedure on the numerical basis only. Furthermore, numerical models were developed and calibrated based on experimental research conducted on longitudinally welded columns by the ECCS committee more than 40 years ago. Research results presented by Wu and Zhang [31] were not considered in the revision process. The production process of aluminium and the welding methods have changed over the years.

By taking into account all above mentioned considerations, the question arises on how reliable are the new design methods for longitudinally welded columns.

Table 2. Overview of experimental research related to stability of longitudinally welded aluminium columns

Paper	Cross-sectional shape	Alloy and temperature	Number of samples	Additional notes
Brungraber and Clark (1962) [26]	Solid rectangular section	AW 5154-H34 AW 5456-H321 AW 6061-T6	No data available	Samples made of longitudinally welded rectangular plates.
Frey (1977) [28]	Type P Type T Type C	AW 6082-T6	11 Type P	Box sections (type C) experienced progressive instability in the out-of-straightness direction. Double T columns (type P and T) experienced sudden buckling more often than progressive buckling due to small initial out-of-straightness.
Faella and Mazzolani (1978) [29]			11 Type T	
			10 Type C	
32				
Wu and Zhang (2011) [31]	I section	AW 6061-T6	20	Specimens failed mostly by flexural buckling. European Code gave more conservative results compared to China Code.

3 Conclusions

Aluminium as a construction material has been in use for more than a century now. Although it cannot compete with steel in terms of price and mechanical properties, aluminium can be a better solution in many situations because of its lower specific weight and corrosion resistance. The use of aluminium as a construction material is currently rising on the global scale, partially owing to the development of modern standards for the design of aluminium structures. Since aluminium structural members are mostly slender and highly susceptible to buckling, stability verification of aluminium members is a mandatory step in the design process. Accordingly, the design of aluminium columns must include verification of flexural buckling. Over the years, the stability of extruded aluminium columns has been well investigated, and Eurocode 9 gives a reliable design procedure for the verification of flexural buckling of such columns. Moreover, the new generation of Eurocode 9 brings a revised and improved design method.

However, the design method for the buckling of longitudinally welded columns, as given in Eurocode 9, is mostly based on the experimental research conducted by the ECCS committee more than forty years ago, and the question arises on the accuracy of these methods. The revised version of Eurocode 9 brings no major im-

provements in this regard, which is primary due to the lack of laboratory testing of longitudinally welded columns. An experimental research on longitudinally welded columns in combination with parametric numerical analyses should be conducted in order to thoroughly assess and revise the verification procedure for longitudinally welded columns given in Eurocode 9. The analysis should focus on many parameters such as boundary conditions, column slenderness, various alloys and tempers, as well as welding procedures. The imperfections of welded aluminium columns and their influence on buckling resistance should also be accounted for. This should also constitute the basis for reliability analysis of a design method given in the new version of Eurocode 9.

References

- [1] Skejić, D.; Boko, I.; Torić, N. Aluminium as a material for modern structures. *Gradevinar* 2015, *67* (11), 1075–1085.
- [2] Dokšanović, T.; Markulak, M.; Džeba, I. State of the art review of the stability and welding of aluminium alloy elements. *Gradevinar* 2014, *66* (2), 1075–1085.
- [3] Mazzolani, F.M. Structural Applications of Aluminium in Civil Engineering. *Struct. Eng. Int.* **2006**, *16*, 280–285.
- [4] Skejić, D.; Orehovec, D.; Ćurković, I. Prefabricated aluminium halls. *Gradevinar* 2021, *73* (2), 141–151.
- [5] Georgantzia, E.; Gkantou, M. Aluminium alloys as structural material: A review of research. *Engineering Structures*. 2021, *227*, 111372.
- [6] Dokšanović, T.; Džeba, I.; Markulak, M. Applications of aluminium alloys in civil engineering. *Tehnički vjesnik* **2017**, *24*(5), 1609-1618.
- [7] Mazzolani, F.M. Aluminium Alloy Structures. 2nd edition, Boca Raton: CRC Press; 1995.
- [8] European Committee for Standardization (CEN). *Eurocode 9: Design of Aluminium Structures—Part 1–1 General structural rules (EN 1999-1-1:2007+A2:2013)*; CEN: Brussels, Belgium, 2007.
- [9] Misiak, T.; Norlin, B.; Höglund, T. European buckling curves for aluminium compression members: A review of proposals for revision. In Proceedings of the Nordic Steel 2019: The 14th Nordic Steel Construction Conference, Copenhagen, Denmark, 18–20 September 2019; pp. 563–570.
- [10] European Committee for Standardization (CEN). *prEN 1999-1-1, Eurocode 9 - Design of Aluminium Structures—Part 1–1 General structural rules*; CEN: Brussels, Belgium, 2020.

- [11] Yuan, H.X.; Wang, Y.Q.; Chang, T.; Du, X.X.; Bu, Y.D.; Shi, Y.J.; Local buckling and postbuckling strength of extruded aluminium alloy stub columns with slender I-sections. *Thin-Walled Structures* 2015, 90, 140–149.
- [12] Misiek, T.; Norlin, B.; Höglund, T. Explanatory notes to buckling design of longitudinally welded aluminium compression members. Proceedings of the SDSS 2019: International Colloquium on Stability and Ductility of Steel Structures, Prague, Czech Republic, 11–13 September 2019.
- [13] Misiek, T.; Norlin, B.; Höglund, T. A look at European buckling curves for aluminium members. *Steel Construction* 2019, 12 (2), 141–155.
- [14] European Committee for Standardization (CEN). *Eurocode 3: Design of steel structures - Part 1-1: General rules and rules for building (EN 1993-1-1:2005)*; CEN: Brussels, Belgium, 2005.
- [15] Osgood, W.R.; Holt, M. The Column Strength of two Extruded Aluminum-Alloy H-sections; Report No.: 656; National Advisory Committee for Aeronautics (NACA), 1938.
- [16] Zhu, J.H. Behaviour and design of aluminum alloy structural members. Doctoral Dissertation, University of Hong Kong, Hong Kong, 2006.
- [17] Zhu, J.H.; Young, B. Tests and design of aluminum alloy compression members. *Journal of structural engineering* 2006, 132 (7), 1096–1107.
- [18] Zhu, J.H.; Young, B. Experimental investigation of aluminum alloy circular hollow section columns. *Engineering Structures* 2006, 28, 207–215.
- [19] Adeoti, G. O.; Fan, F.; Wang, Y. Zhai, X. Stability of 6082-T6 aluminium alloy columns with H-section and rectangular hollow sections. *Thin-walled structures* 2015, 89, 1-16.
- [20] Wang, Y.; Fan, F.; Lin, S. Experimental investigation on the stability of aluminium alloy 6082 circular tubes in axial compression. *Thin-walled structures* 2015, 89, 54-66.
- [21] The Aluminum Association (AA). Aluminum design manual European; AA: Washington DC, 2005.
- [22] Australian/New Zealand Standard. AS/NZS1664.1 - Aluminium structures Part 1: Limit state design. Standards Australia/Standards New Zealand, Sydney, Australia, 1997.
- [23] Wang, Y. Q.; Yuan, H. X.; Chang, T.; Du, X. X.; Yu, M. Compressive buckling strength of extruded aluminum alloy I-section columns with fixed-pinned end conditions. *Thin-walled structures* 2017, 119, 396-403.
- [24] Wang, Z. X.; Wang, Y. Q.; Sojeong, J.; Ouyang, Y. W. Experimental investigation and parametric analysis on overall buckling behavior of large-section aluminum alloy columns. *Thin-walled structures* 2018, 122, 585–596.

- [25] MOHURD. GB 50429 - Code for design of aluminum structures. China Planning Press, Beijing, 2007.
- [26] Hill H. N.; Clark J. W.; Brungraber R. J. Design of Welded Aluminum Structures. *Journal of the Structural Division* 1960, 86(6), 101-124.
- [27] Lai, Y. F. W. Buckling Strength of Welded and Non-welded Aluminium Members. Doctoral Dissertation, Department of Civil and Structural Engineering, University of Sheffield, Sheffield, 1989.
- [28] Frey, F. Alu-alloy welded column buckling research program: test results, ECCS Committee 16, Doc. 16-77-3, 1977.
- [29] Faella, C. Mazzolani, F.M. Buckling behaviour of aluminium alloy welded columns, ECCS Committee 16, Doc. 16-78-2, 1978.
- [30] European Convention for Constructional Steelwork (ECCS)—Technical Committee 2. European Recommendations for Aluminium Alloy Structures; ECCS: Bruxelles, Belgium, 1978.
- [31] Wu, Y.; Zhang, Q. Experimental investigation and design of aluminum columns with longitudinal welds. *Frontiers of Architecture and Civil Engineering in China* 2011, 5(3), 366-373.