

# FASTEST PATH VEHICLE SPEED ANALYSIS AT STANDARD TURBOROUNDBABOUTS WITH VARIOUS APPROACH LEG POSITIONS

---

**Džambas, Tamara; Dragčević, Vesna**

*Source / Izvornik:* **Elektronički časopis građevinskog fakulteta Osijek, 2022, 13, 1 - 11**

**Journal article, Published version**

**Rad u časopisu, Objavljena verzija rada (izdavačev PDF)**

<https://doi.org/10.13167/2022.24.1>

*Permanent link / Trajna poveznica:* <https://um.nsk.hr/um:nbn:hr:237:076216>

*Rights / Prava:* [In copyright](#) / [Zaštićeno autorskim pravom.](#)

*Download date / Datum preuzimanja:* **2024-09-09**

*Repository / Repozitorij:*

[Repository of the Faculty of Civil Engineering,  
University of Zagreb](#)





## FASTEST PATH VEHICLE SPEED ANALYSIS AT STANDARD TURBOROUNDBABOUTS WITH VARIOUS APPROACH LEG POSITIONS

*Scientific paper*

*(Received: 6 January 2021; accepted: 1 December 2021)*

**Tamara Džambas**

*University of Zagreb, Faculty of Civil Engineering, Department of Transportation, Postdoctoral teaching and research associate*

*Corresponding author: [tamara.dzambas@grad.unizg.hr](mailto:tamara.dzambas@grad.unizg.hr)*

**Vesna Dragčević**

*University of Zagreb, Faculty of Civil Engineering, Department of Transportation, Full professor*

**Abstract:** In previous studies, a new (improved) turboroundabout design approach based on the rules of the design vehicle movement geometry was proposed, and the optimal design of elements of standard turboroundabouts for various design vehicle scenarios, circulatory roadway radii, and approach leg positions was defined. Within the scope of this research, the applicability of the current Dutch calculation model for fastest-path vehicle speed analyses at standard turboroundabout schemes designed by a previously described procedure was examined. Research results have shown that this Dutch calculation model does not apply to standard turboroundabouts whose approach legs are aligned under various angles and translatory shifted regarding the roundabout geometric center, and therefore, should not be used for speed analyses at this roundabout type until a new calculation model, which corresponds to the real traffic situation, is developed.

**Keywords:** Standard turboroundabouts; vehicle movement geometry; fastest path; speed analysis; Dutch calculation model.



## 1 INTRODUCTION

The fastest path vehicle speed is the speed a passenger car achieves while taking the straightest possible path through a roundabout, in the absence of other vehicles, and by not respecting the lane markings on the roadway [1]. As stated in [2], speed analysis at roundabouts can be conducted using three different approaches: by measuring the roundabout's geometric features and checking the achieved deflection (German model); by measuring the roundabout's geometric features and then calculating the path radii and vehicle speed (Dutch model); by constructing the fastest paths through the roundabout, measuring the path radii, and then calculating the vehicle speed (American model). Therefore, the choice of roundabout design elements significantly affects the value of this speed, as well as the roundabout capacity and traffic safety [3].

The issue of speeding at roundabouts particularly occurs in double-lane roundabouts, where drivers often intentionally ignore all lane markings and choose the fastest possible path through the circulatory roadway [4-5]. Due to the aforementioned, classic double-lane roundabouts are being used less and less in the design practice in the last few decades and are being replaced with some "safer alternatives" [6-8]. One such "safer alternative" is a turboroundabout - specially designed multi-lane roundabout with spiral circulatory roadway, where the traffic flows at the entrance, circulatory roadway, and exit are physically separated by raised mountable lane dividers [9-10].

Turboroundabouts have two principal advantages over conventional double-lane roundabouts, based on the physical separation of the lanes: a) reduction in the number of conflict points; b) speed reduction along the entry, circulatory, and exit zones [11-12]. The inventor of turboroundabouts, L.G.H. Fortuijn, states that the vehicle speed in turboroundabouts is notably lower than in double-lane roundabouts (up to 50 km/h for roundabouts with small inner radii) and quite similar to the vehicle speed in single-lane roundabouts [9]. The authors of the study [13] explained that the main reason for such an occurrence is the specific path curvature, which is the inverse of the radius, and that driving inconvenience increases with centripetal acceleration, which is in direct correlation with curvature. Petru and Krivda stressed that vehicle speed in turboroundabouts depends significantly on the choice of dimensions of its design elements (turbo block size and position, circulatory roadway inner radii, width of splitter islands, entry and exit radii) and that wide circulatory lanes frequently lead to high driving speeds at the circulatory roadway [14].

According to the majority of existing regulations for the design of turboroundabouts, Dutch guidelines [15], Slovenian technical specifications [16], Serbian design manual [17], and Croatian guidelines [18], fastest path vehicle speed analyses are carried out, together with horizontal swept path analyses, at the end of the design process using a Dutch calculation model. If these analyses show that the applied elements do not fulfill the swept path and/or speed requirements, a redesign of roundabout elements is indispensable. On the other hand, German working document [19] does not require verification of the fastest path vehicle speed after all turboroundabout elements are designed.

In previous studies [20-22] the main shortcomings of previously described turboroundabout design procedures, which may lead to oversized or undersized turboroundabout solutions, were analyzed, and a new (improved) turboroundabout design approach based on the rules of the design vehicle movement geometry was proposed. As a result, the optimal design of elements of standard turboroundabouts (Figure 1) for various design vehicle scenarios, circulatory roadway radii, and approach leg positions was defined [23-25].

Within the scope of this research, the applicability of the Dutch calculation model for fastest-path vehicle speed analyses at standard turboroundabout schemes designed by a previously described procedure was examined.

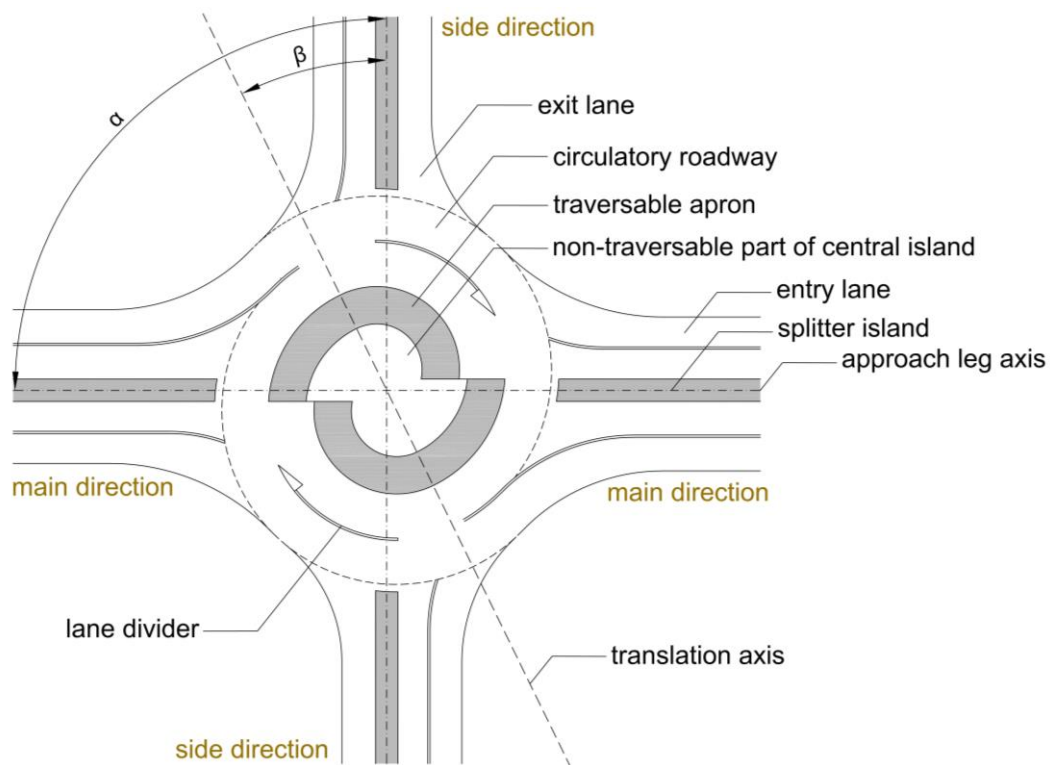

Figure 1 Elements of standard turboroundabout

## 2 METHODOLOGY

The optimal design of elements of standard turboroundabouts (turbo block, circulatory roadway, central island, approach leg elements, raised mountable lane dividers) was defined based on the results of extensive swept path analyses carried out through the six basic steps shown in Figure 2. As stated in the Introduction, multiple influential parameters were considered in these analyses:

- 3 design vehicle scenarios: a two-axle truck with a three-axle semitrailer, a three-axle bus, and both aforementioned design vehicles (Figure 3a);
- 11 circulatory roadway (turbo block) inner radii values:  $11 \text{ m} \geq R_1 \geq 21 \text{ m}$  ( $\Delta=1 \text{ m}$ ) (Figure 3b);
- 23 different approach leg positions: radial alignment at angles of  $75^\circ \geq \alpha \geq 105^\circ$  ( $\Delta=5^\circ$ ), translational shift to the right  $+1 \text{ m} \geq O_R \geq +8 \text{ m}$  ( $\Delta=1 \text{ m}$ ), and translational shift to the left  $-1 \text{ m} \geq O_L \geq -8 \text{ m}$  ( $\Delta=1 \text{ m}$ ) (Figure 3b).

Consequently, a total of 759 initial standard turboroundabout schemes with various turbo block dimensions and approach leg positions were created, of which only 161 fulfilled the swept path requirements. Even though three design vehicle scenarios were observed in this study, both trucks with semitrailers and intercity buses are commonly present in traffic networks in suburban areas where turboroundabouts are usually planned. Therefore, the dimensions of the design elements that fulfilled the swept path requirements of both vehicles mentioned above were recommended for use in the design practice (Table 1).

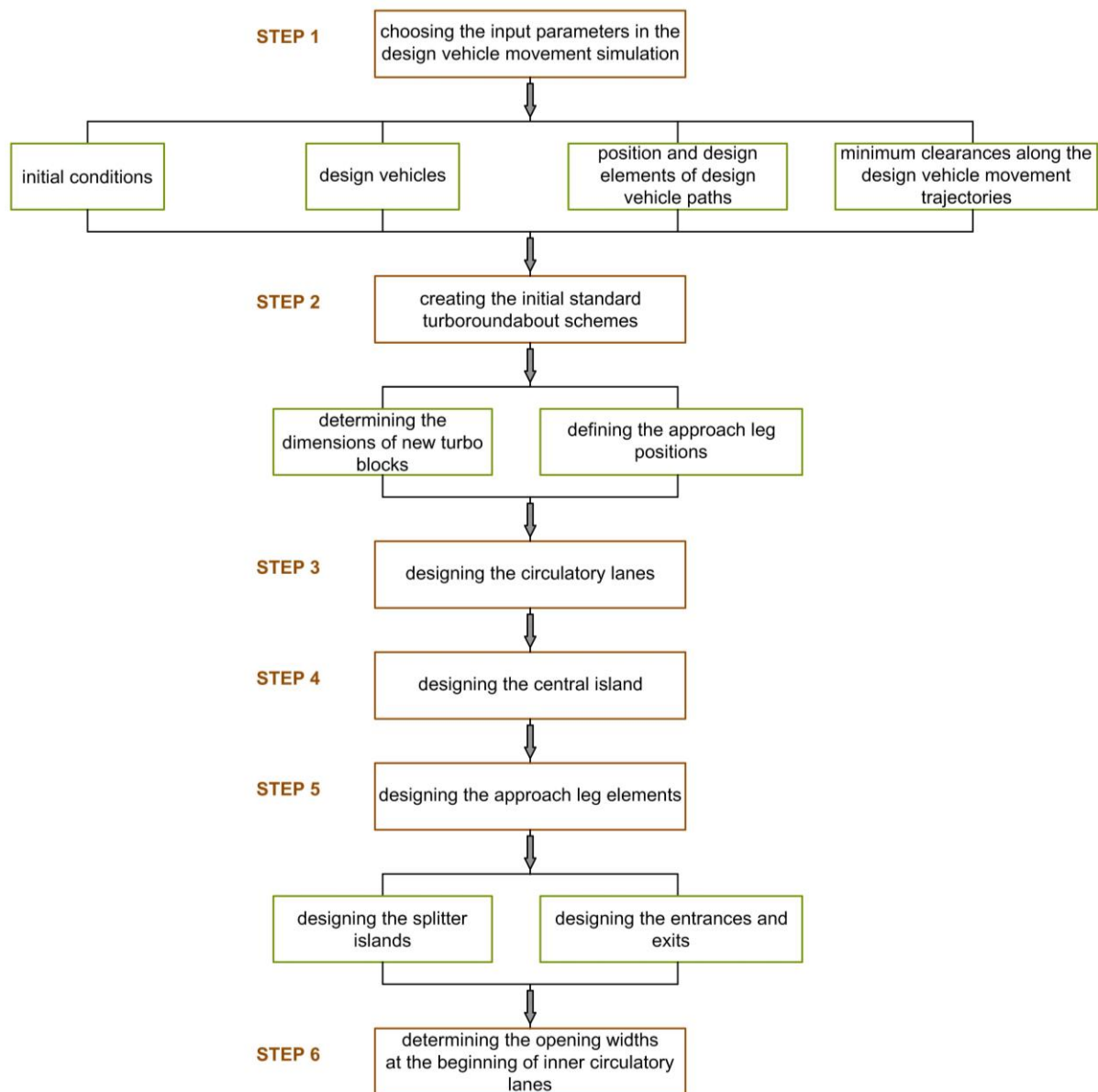

**Figure 2 Design procedure based on the design vehicle movement geometry**

Finally, it should be emphasized that all input parameters and limit dimensions of individual turboroundabout elements applied in the previously described design procedure were chosen based on the recommendations of current regulations for the design of roundabouts and turboroundabouts and detailed analysis of scientific and professional literature from the subject area, and that the dimensions of the design elements of turboroundabout schemes that fulfilled the swept path requirements are given in previous studies [23-25].

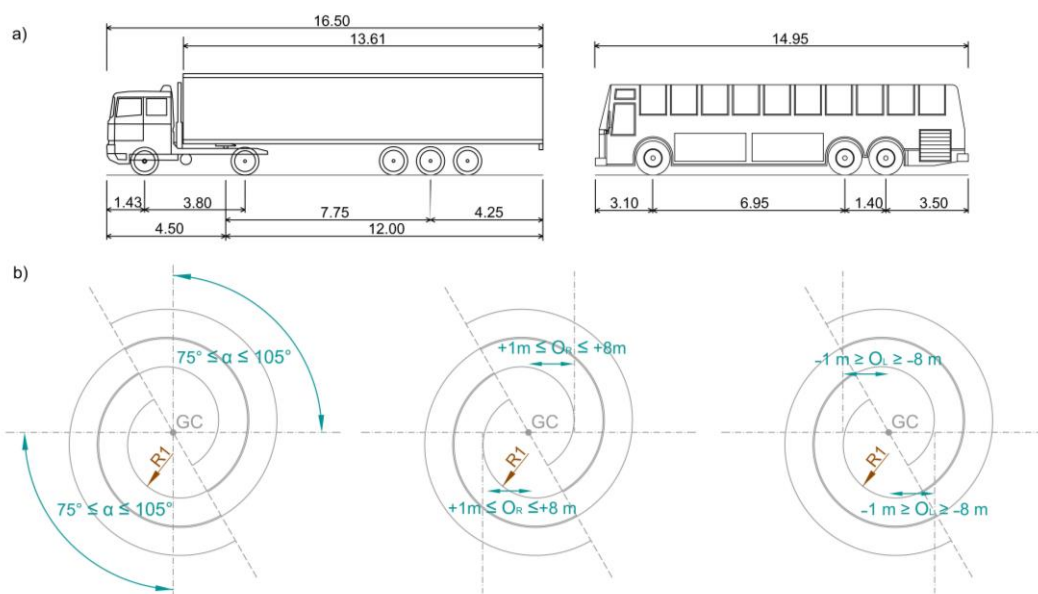

**Figure 3 Influential parameters considered in the analyses: a) relevant design vehicles, b) inner radius and approach leg positions**

**Table 1 Recommended standard turboroundabout radii and approach leg positions**

Inner radius R1 [m]	Approach leg positions		
	$\alpha$ [°]	$O_R$ [m]	$O_L$ [m]
20	75 – 105	1 – 4	(-1) – (-8)
21	75 – 105	1 – 4	(-1) – (-8)

## 2.1 Construction of vehicle fastest paths

Speed analyses at standard turboroundabout schemes that fulfilled the swept path requirements (Table 1) were conducted using the Dutch calculation model. The analyses were carried out for through movement, right turn from the outer entry lane, and right turn from the inner entry lane. Consequently, twelve fastest vehicle paths were constructed for each standard turboroundabout scheme, taking into account the recommended distance of 1 m from potential points of impact (roadway edges and raised mountable lane dividers):

- 6 fastest paths for through movement, consisting of three reverse circular arcs of the same radius (Figure 4a);
- 4 fastest paths for right turn from the outer entry lane, consisting of one circular arc (Figure 4b);
- 2 fastest paths for right turn from the inner entry lane, consisting of one circular arc (Figure 4c).

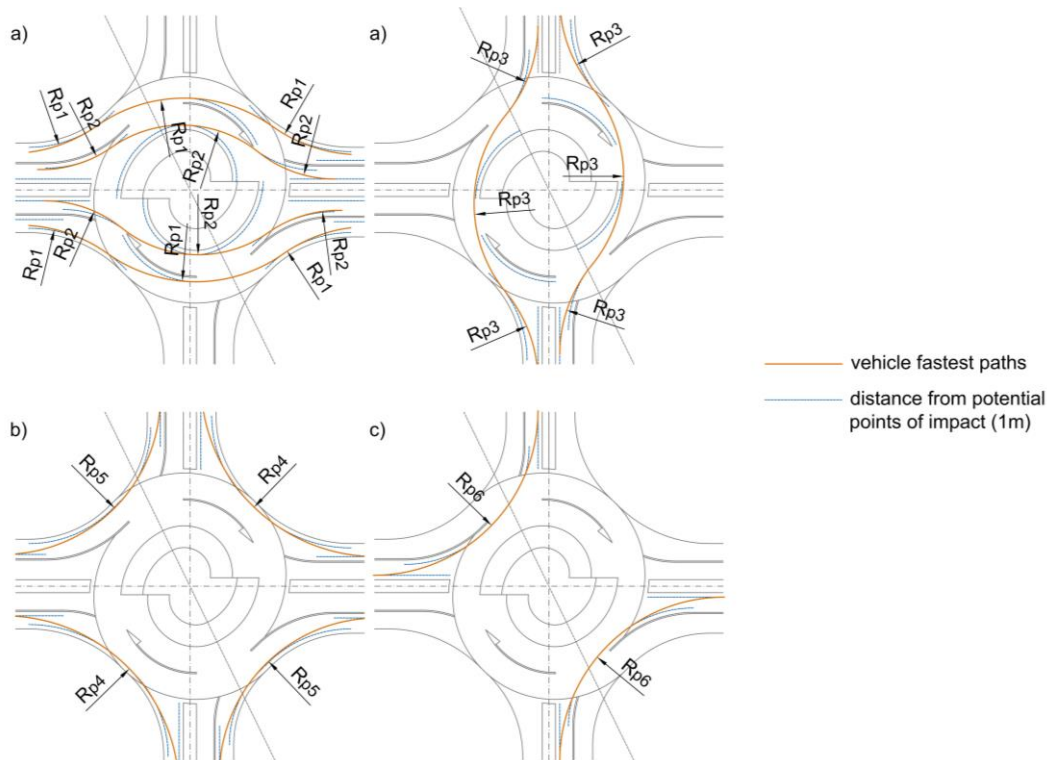

**Figure 4 Construction of vehicle fastest paths for: a) through movements, b) right turn from the outer entry lane, c) right turn from the inner entry lane**

According to the Dutch calculation model, the values of circular arc radii at the fastest paths for through movements in the main driving direction ( $R_{p1}$ ,  $R_{p2}$ ,  $R_{p3}$ ) should be determined using equation (1). In contrast, the values of circular arc radii at the fastest paths for right turns ( $R_{p4}$ ,  $R_{p5}$ ,  $R_{p6}$ ) should be determined iteratively with respect to the recommended distance from potential points of impact. As stated in [18], number of aforementioned potential points of impact depends on the alignment of the roundabout approach legs and the fastest path shape.

$$R_{p1} = R_{p2} = R_{p3} = \frac{(0.25 \cdot L)^2 + (0.5 \cdot (U + 2))^2}{U + 2} \quad (1)$$

where  $R_{p1}$ ,  $R_{p2}$ , and  $R_{p3}$  are the radii of the circular arcs at the fastest paths for through movements in the main driving direction [m],  $L$  is the distance between the start point of the roundabout entry radius and the endpoint of the roundabout exit radius [m], and  $U$  is the deviation i.e. the distance between the central island/raised mountable lane divider and the tangent ( $L$ ) between the roundabout entry and exit radius (Figure 5).

In this research, the values of circular arc radii at the fastest paths for through movements in the side driving direction ( $R_{p3}$ ) could not be constructed using equation (1) because of the various positions of the turboroundabout approach legs in that driving direction. Namely, when turboroundabout approach legs were not aligned radially under the angles of  $90^\circ$ , the tangents ( $L$ ) between the roundabout entry and exit radii, and the deflections ( $U$ ) could not be defined properly i.e. they could not be defined in accordance with the recommendations provided in the regulations [15-18]. In light of the above considerations, values of circular arc radii ( $R_{p3}$ ) were also determined iteratively with respect to the recommended distance from potential points of impact.



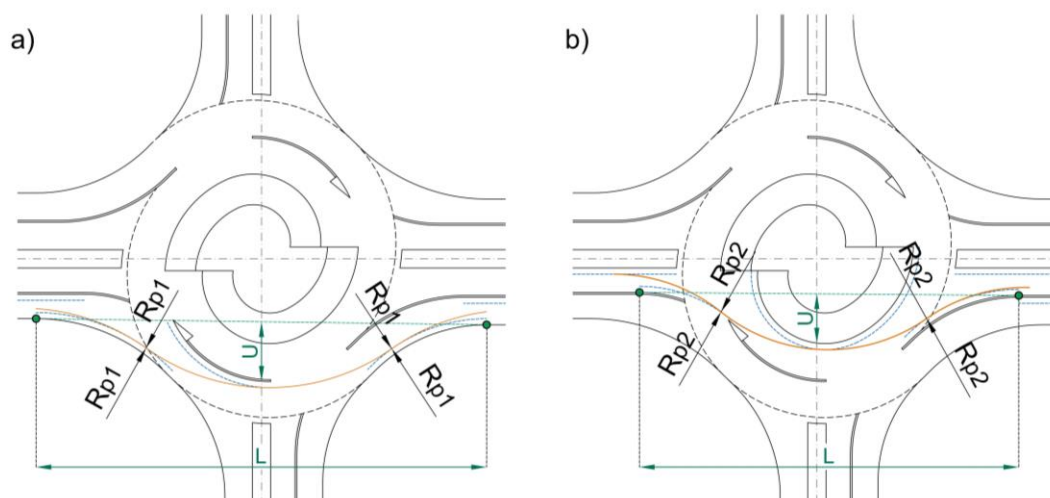

**Figure 5 Determination of circular arc radii at fastest paths for through movements using the eq. (1): a) paths through outer circulatory lanes, b) paths through inner circulatory lanes**

## 2.2 Calculation of vehicle speed

The vehicle speed at the fastest paths constructed by the previously described procedure was calculated using equation (2). These calculated speed values were then analyzed and compared with the maximum recommended speed values given in existing regulations for the design of turboroundabouts [15-18] (Table 2).

$$V_i = 7.4 \cdot \sqrt{R_{pi}} \tag{2}$$

where  $V_i$  is the vehicle speed at the fastest path  $R_{pi}$  [km/h] and  $R_{pi}$  is the radius of the circular arc at the fastest path  $i$  [m].

**Table 2 Range of maximum speed values at turboroundabouts**

Maximum speed	Approach leg positions			
	NL [15]	SI [16]	RS [17]	HR [18]
recommended	37	35	35	35
highest	40	37	37	37

## 3 RESEARCH RESULTS

The results of speed analyses carried out on standard turboroundabout schemes that fulfilled the swept path requirements using a Dutch calculation model are shown in Figure 6 and Table 3. As it can be seen, on 31 of a total of 38 standard turboroundabout schemes (81% of cases) at least one of the fastest paths for a right turn could not be constructed, and the main reason for this were the raised mountable lane dividers located between the traffic lanes at the roundabout approach legs and circulatory roadway. This especially occurred in turboroundabout schemes on which approach leg angle values were varied and turboroundabout schemes on which approach legs were translatory shifted to the left.



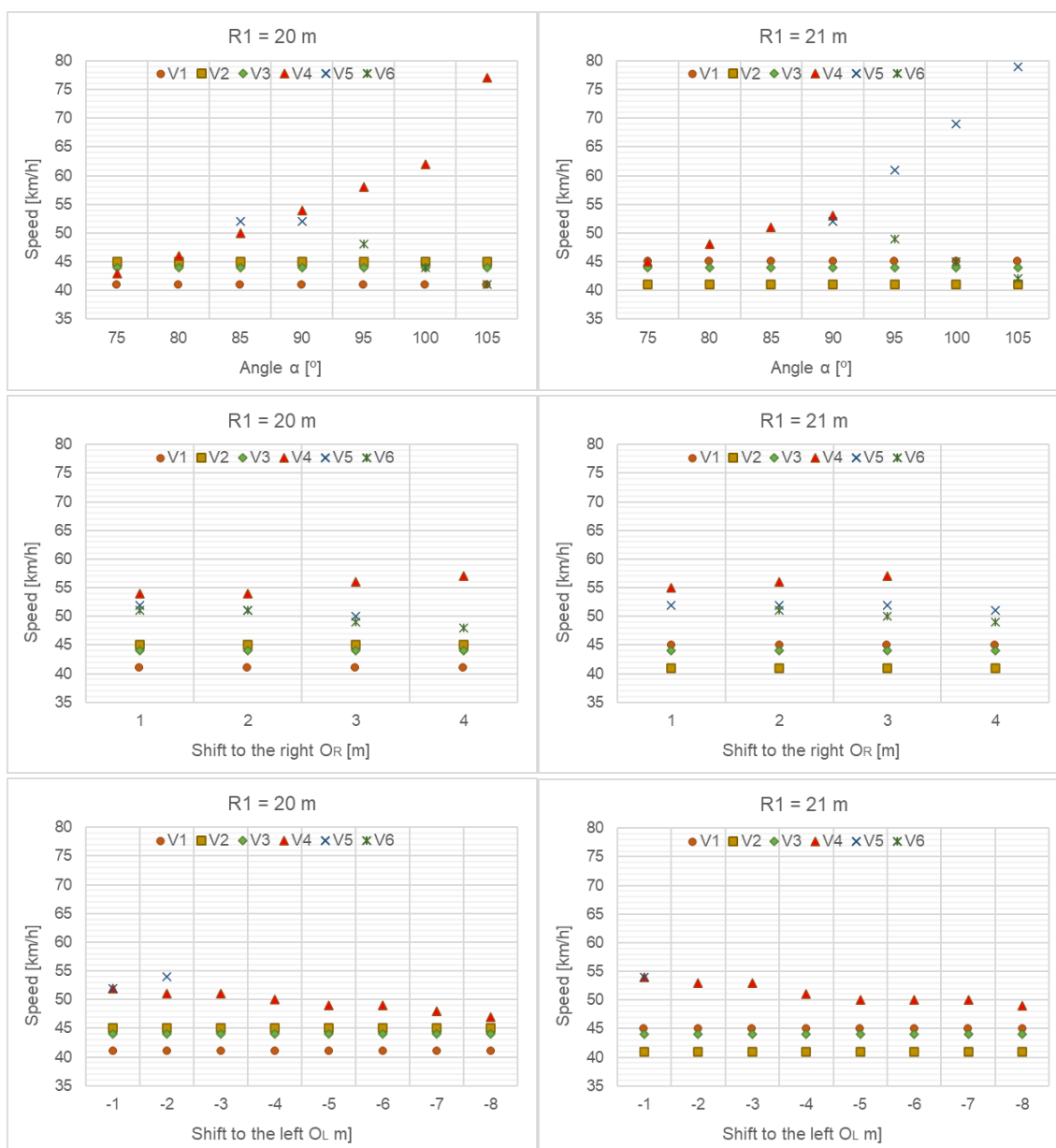

**Figure 6 Results of speed analyses carried out on standard turboroundabout schemes which fulfilled the swept path requirements**

Furthermore, speed values on the fastest paths for through movements (V1, V2, V3) were not affected by the change in approach leg positions, and they ranged from 41 to 45 km/h. On the fastest paths for right turns (which could be constructed), speed values (V4, V5, V6) were notably greater, especially when the approach leg angle values were varied. The following relations between the speed values on the fastest paths for right turns, and approach leg positions were identified:

- The value of speed V4 increases with an increase of the values of the approach leg’s angles and an increase of the values of translatory shifts to the right, and decreases with an increase of the values of translatory shifts to the left;
- The value of speed V5 increases with an increase of the values of the approach leg’s angles, and decreases with an increase of the values of translatory shifts to the right;
- The value of speed V6 decreases with an increase of values of approach leg angles and an increase of the values of the translatory shifts to the right.



**Table 3 Summarized results of speed analyses**

Inner radius R1 [m]	Approach leg positions							
	$\alpha$ [°]							
	75	80	85	90	95	100	105	
20	(-)2,3	(-)2,3	(-)3	(-)3	(-)2	(-)2	(-)2	
21	(-)2,3	(-)2,3	(-)2,3	(-)3	(-)1	(-)1	(-)1	
	$O_R$ [m]							
	+1		+2		+3		+4	
20	(+)		(+)		(+)		(-)2	
21	(-)3		(+)		(+)		(-)1	
	$O_L$ [m]							
	-1	-2	-3	-4	-5	-6	-7	-8
20	(-)3	(-)3	(-)2,3	(-)2,3	(-)2,3	(-)2,3	(-)2,3	(-)2,3
21	(-)3	(-)2,3	(-)2,3	(-)2,3	(-)2,3	(-)2,3	(-)2,3	(-)2,3

(-)1 - fastest paths for right turn with radius R4 could not be constructed

(-)2 - fastest paths for right turn with radius R5 could not be constructed

(-)3 - fastest paths for right turn with radius R6 could not be constructed

(+) - all fastest paths were constructed

The relation between the speed values on the fastest paths for right turns with radii R5 and R6 and approach leg translatory shifts to the left could not be defined because most of these paths could not be constructed for these approach leg positions.

#### 4 DISCUSSION AND CONCLUSIONS

Research results have shown that the Dutch calculation model for speed analyses, recommended by majority of existing regulations for the design of turboroundabouts [15-18], does not apply to standard turboroundabouts with various approach leg positions. As stated earlier, in 81% of cases, at least one of the fastest paths for a right turn could not be constructed at such turboroundabouts, and the main reason for this were the raised mountable lane dividers located between the traffic lanes at the roundabout approach legs and circulatory roadway. In addition, the values of circular arc radii at the fastest paths for through movements in the side driving direction ( $R_{p3}$ ) could not be constructed using equation (1), also due to the raised mountable lane dividers i.e. various positions of turboroundabout approach legs in that driving direction.

It should be noted that this Dutch calculation model was initially used for speed analyses at classic single-lane roundabouts [16, 26-28], and afterwards, the same guidelines for the construction of vehicle fastest paths and calculation of fastest path vehicle speed were provided in the current regulations for the design of turboroundabouts [15-18]. Extensive research [29] carried out at several single-lane roundabouts in Croatia has shown that the theoretical fastest paths and speed values determined by means of previously described calculation model significantly differ from those determined by means of field measurements. Apart from that, a certain number of theoretical fastest paths could not be constructed, also due to the specific positions of the approach legs at these roundabouts. As a result, a new calculation model for speed analyses at single-lane roundabouts, which corresponds to the real traffic situation, was proposed in the aforementioned research.

Furthermore, it should be emphasized that observed regulations for the design of turboroundabouts [15-18] are providing predetermined dimensions of basic design parameters (turbo block parameters) for turboroundabouts whose approach legs are aligned radially at angles of 90°. The author of the study [30] has indicated that such approach legs are often difficult to plan, especially in the case of reconstruction of existing road intersections located at sites with significant spatial limitations, and that the main shortcoming of existing roundabout design procedures is that they do not consider the impact of various approach leg positions on fastest path vehicle speed values. Accordingly, maximum recommended speed values given in Table 2 could not be achieved in this study either.

In the light of the above considerations, the following conclusions can be made:



- The Dutch calculation model for speed analyses does not apply to standard turboroundabouts whose approach legs are aligned under various angles i.e. translatory shifted regarding the roundabout geometric center;
- Consequently, a new calculation model for speed analyses at turboroundabouts, which corresponds to the real traffic situation, should be developed, and a revision of existing regulations for the design of turboroundabouts should be considered.

Until this new calculation model is developed, the driving speed at existing turboroundabouts could perhaps be reduced by applying other speed control measures, such as installing vertical traffic calming devices at roundabout approaches, speed radars, etc. Finally, it is questionable whether the speed limits given in Table 2 can be achieved at all at these specially designed multi-lane roundabouts with large diameters, which are, in most cases, constructed in suburban areas. According to German working document, which is one of the newest regulations for the design of turboroundabouts, properly designed turboroundabout should only fulfill the swept path requirements, and fastest-path vehicle speed analyses are not required.

## References

- [1] Pilko, H.; Brčić, D.; Šubić, N. 2014: Study of vehicle speed in the design of roundabouts, *Građevinar*, 66 (5), pp. 407-416. <http://dx.doi.org/10.14256/JCE.887.2013>
- [2] Ahac, S.; Džambas, T.; Dragčević, V. 2016: Review of fastest path procedures for single-lane roundabouts, *Road and Rail Infrastructure IV*, Proceedings of the 4<sup>th</sup> International Conference CETRA 2016, Lakušić, S. (Ed.), Department of Transportation, Faculty of Civil Engineering, University of Zagreb, pp. 885-891, Šibenik, Croatia.
- [3] Rodegerdts, L. et al. 2010: Roundabouts: An Informational Guide, 2nd Edition, NCHRP Report 672, National Cooperative Highway Research Program, Washington DC, USA.
- [4] Engelsman, J. C.; Uken, M. 2007: Turbo Roundabouts as an Alternative to Two Lane Roundabouts, The challenges of implementing policy?, Proceedings of the 26<sup>th</sup> Southern African Transport Conference (SATC 2007), pp. 581-589, Pretoria, South Africa.
- [5] Tollazzi, T.; Renčelj, M.; Turnšek, S. 2011: New Type of Roundabout: Roundabout with “Depressed” Lanes for Right Turning – “Flower Roundabout”, *Promet – Traffic&Transportation*, 23 (5), pp. 353-358. <http://dx.doi.org/10.7307/ptt.v23i5.153>
- [6] Tollazzi, T.; Jovanović, G.; Renčelj, M. 2013: New Type of Roundabout: Dual one-lane roundabouts on two levels with right-hand turning bypasses – “Target roundabout”, *Promet – Traffic&Transportation*, 25 (5), pp. 475-481. <http://dx.doi.org/10.7307/ptt.v25i5.1230>
- [7] Tollazzi, T.; Renčelj, M. 2014: Comparative Analyse of the Two New Alternative Types of Roundabouts – Turbo and Flower Roundabout, *The Baltic Journal of Road and Bridge Engineering*, 9 (3), pp. 164-170. <http://dx.doi.org/10.3846/bjrbe.2014.21>
- [8] Džambas, T.; Dragčević, V.; Benci, D. 2020: Modern suburban roundabouts in Croatia - flower and turbo roundabouts, *Scientific Journal of Civil Engineering*, 9 (2); pp. 9-14.
- [9] Fortuijn, L. G. H. 2009: Turbo Roundabouts: Design Principles and Safety Performance, *Transportation Research Record: Journal of the Transportation Research Board*, 2096 (1), pp. 16-24. <http://dx.doi.org/10.3141/2096-03>
- [10] Fortuijn, L. G. H. 2013: Turborotonde en turboplein: Ontwerp, capaciteit en veiligheid, Doctoral Thesis, Delft University of Technology, Faculty of Civil Engineering and Geosciences, Delft, Netherlands. Available at: <https://repository.tudelft.nl/islandora/object/uuid:e01364ce-78de-465b-a8c8-39e28a4585dd>
- [11] Corriere, F.; Guerrieri, M. 2012: Performance Analysis of Basic Turbo-Roundabouts in Urban Context, *Procedia - Social and Behavioral Sciences*, 53, pp. 622-632. <http://dx.doi.org/10.1016/j.sbspro.2012.09.912>
- [12] Guerrieri, M.; Ticali, D.; Corriere F. 2012: Turbo roundabouts: geometric design parameters and performance analysis, *GSTF Journal on Computing (JoC)*, 2 (1), pp. 227-232.
- [13] Bastos Silva, A.; Vasconcelos, L.; Santos, S. 2014: Moving from Conventional Roundabouts to Turbo-Roundabouts, *Procedia - Social and Behavioral Sciences*, 111, pp. 137-146. <https://doi.org/10.1016/j.sbspro.2014.01.046>



- [14] Petru, J.; Krivda, V. 2021: An Analysis of Turbo Roundabouts from the Perspective of Sustainability of Road Transportation, *Sustainability*, 13 (4), pp. 1-26. <https://doi.org/10.3390/su13042119>
- [15] CROW 2008: Turborotondes, Publication No. 257, Dutch Technology Platform for Transport, Infrastructure and Public Space, Ede, Netherlands.
- [16] MTRS 2011: Roundabouts with a Spiral Course of the Circulatory Roadway, Draft No. TSC 03.XXX, Ministry of Transport Republic of Slovenia, Ljubljana, Slovenia.
- [17] SAR 2012: Manual for Road Design in Republic of Serbia - Part 5.3., Roundabouts, Serbian Authority for Roads, Belgrade, Serbia.
- [18] CAR 2014: Guidelines for Design of Roundabouts with Spiral Circulatory Roadway on State Roads, Croatian Authority for Roads, Rijeka, Croatia.
- [19] FGSV 2015: Working Document on Turbo Roundabouts, Research Association for Roads and Transportation, Cologne, Germany.
- [20] Džambas, T.; Ahac, S.; Dragčević, V. 2016: Geometric design of turbo roundabouts according to Croatian and Dutch guidelines, *Proceedings of 4th International Conference CETRA 2016*, Lakušić, S. (Ed.), Department of Transportation, Faculty of Civil Engineering, University of Zagreb, pp. 893-900, Šibenik, Croatia.
- [21] Džambas, T.; Ahac, S.; Dragčević, V. 2016: Design of turbo roundabouts based on the rules of vehicle movement geometry, *Journal of Transportation Engineering*, 142 (7), pp. 1-12. [http://dx.doi.org/10.1061/\(ASCE\)TE.1943-5436.0000850](http://dx.doi.org/10.1061/(ASCE)TE.1943-5436.0000850)
- [22] Džambas, T.; Ahac, S.; Dragčević, V. 2017: Geometric design of turbo roundabouts, *Tehnički vjesnik-Technical Gazette*, 24 (1), pp. 309-318. <http://dx.doi.org/10.17559/TV-20151012162141>
- [23] Džambas, T. 2018: Design of standard turboroundabouts, Doctoral Thesis, University of Zagreb, Faculty of Civil Engineering, Zagreb, Croatia.
- [24] Džambas, T.; Dragčević, V.; Korlaet, Ž. 2020: Optimizing Geometric Design of Standard Turboroundabouts, *KSCE Journal of Civil Engineering*, 24 (57), pp. 3034-3049. <http://dx.doi.org/10.1007/s12205-020-1689-3>
- [25] Džambas, T.; Dragčević, V.; Korlaet, Ž. 2020: Prijedlog novog postupka oblikovanja turbokružnih raskrižja, *Ceste i mostovi: glasilo Hrvatskog društva za ceste*, 12 (2020), pp. 78-89. [in Croatian]
- [26] CROW 1998: Eenheid in rotondes, Publication No. 126, Dutch Technology Platform for Transport, Infrastructure and Public Space, Ede, Netherlands.
- [27] MTRS 2011: Roundabouts, Publication No. TSC 03.341, Ministry of Transport Republic of Slovenia, Ljubljana, Slovenia.
- [28] CAR 2014: Guidelines for Design of Roundabouts on State Roads, Croatian Authority for Roads, Rijeka, Croatia.
- [29] Šurdonja, S.; Deluka Tibljaš, A.; Dragčević, V. 2018: Analyses of maximum-speed path definition at single-lane roundabouts, *Journal of Traffic and Transportation Engineering (English Edition)*, 5 (2), pp. 83-95. <http://dx.doi.org/10.1016/j.jtte.2017.06.006>
- [30] Chan, S. 2017: Radial, Left or right Offset Alignment and Roundabout Vehicle speeds, *Roundabouts Now*, 3, pp. 24-27.

Please cite this article as: Džambas, T., Dragčević, V.: Fastest path vehicle speed analysis at standard turboroundabouts with various approach leg positions, *Electronic Journal of the Faculty of Civil Engineering Osijek-e-GFOS*, 2022, 24, pp. 1-11, <https://doi.org/10.13167/2022.24.1>