

Analyses of maximum-speed path definition at single-lane roundabouts

Šurdonja, Sanja; Dragčević, Vesna; Deluka-Tibljaš, Aleksandra

Source / Izvornik: **Journal of Traffic and Transportation Engineering (English Edition), 2018, 5, 83 - 95**

Journal article, Published version

Rad u časopisu, Objavljena verzija rada (izdavačev PDF)

<https://doi.org/10.1016/j.jtte.2017.06.006>

Permanent link / Trajna poveznica: <https://urn.nsk.hr/urn:nbn:hr:237:551432>

Rights / Prava: [In copyright](#)/[Zaštićeno autorskim pravom.](#)

Download date / Datum preuzimanja: **2025-03-17**

Repository / Repozitorij:

[Repository of the Faculty of Civil Engineering,
University of Zagreb](#)

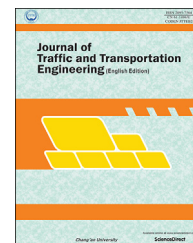

Available online at www.sciencedirect.com

journal homepage: www.elsevier.com/locate/jtte

Original Research Paper

Analyses of maximum-speed path definition at single-lane roundabouts

Sanja Šurdonja^{a,*}, Vesna Dragčević^b, Aleksandra Deluka-Tibljaš^a

^a Faculty of Civil Engineering, University of Rijeka, Rijeka 51000, Croatia

^b Faculty of Civil Engineering, University of Zagreb, Zagreb 10000, Croatia

HIGHLIGHTS

- Models for roundabout speed provide speeds substantially different from measured.
- Developed methodology enables precise definition of vehicle path and speed.
- This article experimentally determines path elements, which is different from those recommended by the USA guidelines.
- Vehicle path is the basis for development of new operating speed model.

ARTICLE INFO

Article history:

Received 6 April 2017

Received in revised form

26 June 2017

Accepted 27 June 2017

Available online 9 April 2018

Keywords:

Traffic safety

Operational speed

Roundabout

Speed path definition

Model

ABSTRACT

The process of designing roundabouts is an iterative process through which, in several checks, the design elements of a roundabout get optimized. Existing regulations for roundabouts involve swept path analyses, sight distance analyses and speed analyses of vehicles passing through the roundabout. Speed analyses are done mostly based on two models, Dutch and American. Each of these two models, in their own way takes into account design elements of the roundabouts, and the US model also envisions the construction of vehicle paths through the roundabout. Main assumption of both models is that vehicle paths through roundabouts consist of few connected radii. US models for path definition takes into account safety distances from marked lines and geometric elements (curbs) at the entrance and exit and through roundabout. Experimentally determined elements of the vehicle path through the roundabout, do not correspond to those recommendations. Comparison of the measured speed at the roundabouts and speed calculated according to aforementioned models at several roundabouts in Croatia, showed a significant difference. An experimental research was conducted as a first step in developing a new model for operating speed through roundabouts. The research aimed to define the basic path elements of vehicle movement in the roundabout at which the maximum speed is achieved. Results of the study are presented in this paper.

© 2018 Periodical Offices of Chang'an University. Publishing services by Elsevier B.V. on behalf of Owner. This is an open access article under the CC BY-NC-ND license (<http://creativecommons.org/licenses/by-nc-nd/4.0/>).

* Corresponding author. Tel.: +385 5 1265900.

E-mail addresses: sanja.surdonja@uniri.hr (S. Šurdonja), vesnad@grad.hr (V. Dragčević), aleksandra.deluka@uniri.hr (A. Deluka-Tibljaš).

Peer review under responsibility of Periodical Offices of Chang'an University.

<https://doi.org/10.1016/j.jtte.2017.06.006>

2095-7564/© 2018 Periodical Offices of Chang'an University. Publishing services by Elsevier B.V. on behalf of Owner. This is an open access article under the CC BY-NC-ND license (<http://creativecommons.org/licenses/by-nc-nd/4.0/>).

1. Introduction

During last decades, roundabouts have been successfully implemented as a solution for intersection reconstruction in the cases where there are problems with traffic safety (Elvik, 2003; Jensen, 2013; Retting et al., 2001) or capacity (Kennedy et al., 2005). In their overview of roundabout design and practices, authors came to the conclusion that geometric design criteria have fundamental importance to achieve the best performance of roundabouts in terms of both capacity and safety (Montella et al., 2013). Geometric elements for roundabout design are usually defined through official, mostly national design standards and/or guidelines in which an overview of important geometric elements together with their average values is given. To assure the consistency of chosen geometric elements, roundabout design is then optimized through an iterative process which includes check-up of path-alignment for chosen design vehicle, check-up of sight distance conditions at the entrance and in the roundabout and check-up of operating speed through roundabout. Researches done on roundabouts show that higher operating speeds at the entrance, in the middle of roundabout and at the exit of roundabout can result in traffic accidents and low speeds can negatively affect roundabout capacity or capacity of corridor with more roundabouts in line. Analyses of traffic accidents on roundabouts conducted as a part of extensive studies in USA proved that more than 65% of the most part of the accidents that happen on roundabouts in different parts of the world (Rodegerdts et al., 2010), happened during negotiations at the entrance of the roundabout, loose of control at the entrance and in the roundabout or as rear-end crashes when vehicles brake suddenly at the exit. Analyses of the reasons for those accidents conducted in the same study show that they are different but that in all cases the problem is operating speed of vehicles that participated in the accident.

Comparative study done on the sample of roundabouts in four Middle-European countries (Checkia, Hungary, Poland, Slovakia) was based on the analyses of accidents, traffic and geometry data. According to the finally developed accident prediction model in that study, injury accident frequency is positively associated with effect of traffic volume and apron width, while negatively associated to deflection in terms of both entry and deviation angles (Ambros et al., 2016). A similar study was conducted in South Korea, where the authors have developed a model that predicts an accident at the traffic intersection, solely on the basis of geometric elements intersection (Kim and Choi, 2013).

In their paper about models for relating roundabouts safety to predicted speed authors defined approach average speed (defined as average speed on entry, upstream circulating and exit speed) to be the speed that best predicts safety on roundabouts (Chen et al., 2013).

The conclusion in USA guidelines is that speed represents a fundamental issue for road design and traffic engineering studies, and it is considered as the most important variable in roundabout geometric design (FHWA, 2000). Roundabout design is iterative process in which the selection of geometric parameters highly depends on design speed,

estimation of roundabout functionality (safety, capacity) and optimization of the design depends on operational speed. Operational speed on roundabouts can be defined as speed achieved from most of the users while driving through roundabout. When new roundabout is designed, operational speed can be established by using one of the other models for existing roundabouts operational speed (Bassani and Sacchi, 2012). Operational speed is commonly defined as 85% of cruising speed on road section in defined conditions (AASHTO, 2001). In literature, 85% of cruising speed shows the speed of the most conservative driver and that is the reason why it is accepted as operational speed comparing with design speed. The difference between design and operational speed has to be minimum to assure expectations of the most accurate drivers (Bassani et al., 2014). Researches show that speeds measured on road network are often significantly higher than design speeds and also higher than allowed speeds (Wang et al., 2006). Previous research concluded that operational speed at roundabouts highly depends on the vehicle path through the roundabout. Montella et al. (2012) emphasized in their overview on application of entry path radius at roundabouts that the fastest path allowed by the geometry is “the smoothest, flattest path that a vehicle can take through the entry, round the central island and thorough the exit in absence of other traffic”. Al-Ohmari et al. (2014), on the basis of filed investigation on 30 roundabouts, concluded that the average and 85% roundabout circulating speeds are directly proportional to the upstream approach free flow speed, entry width, internal circle diameter, and drive curve, while they are inversely proportional with entry angle.

Silva et al. (2014) in their paper presented a different method of gathering data about vehicles' speed through double-lane roundabout by using a data logger device. Regression analysis showed that roundabout influence zone and entry speed at double-lane roundabouts are strongly related to the approach speed, but some other geometric elements of the roundabouts are statistically significant as well.

In their paper, Easa and Mehmood (2004) presented their model of consistency for roundabouts which is based on the analyses of vehicle path through roundabout (straight, left and right path) in order to assure conflicting and consecutive speed is up to be 20 km/h.

Procedures for estimating design-vehicle path and speed are defined in most of the existing national regulations for roundabouts design. In the following research analyses of following regulations have been done: USA (FHWA, 2000), Australian (Velth and Arndt, 2011), UK (HA, 2007), Netherlands (CROW, 1998; DMT, 2009), Slovenia (MPRS, 2011), Serbia (PS, 2012) and Croatia (HC, 2014).

Models that are used for speed definition in the procedures defined for speed control at roundabouts can be divided in two main groups:

- models based on the calculation of the speed in horizontal curve suggested in FHWA (2000), developed in AASHTO (2001) – FHWA model.
- models based on the correlation of basic design elements suggested in CROW (1998), HC (2014), MPRS (2011) and PS (2012) – CROW model.

Main assumption of both models is that vehicle paths through roundabouts consist of few connected radii. Models for path definition take into account safety distances from marked lines and geometric elements (curbs) in the entrance and through roundabouts. As geometric elements are differently defined in guidelines, the result of path definition also varies depending on which regulation is used. Exception in speed control procedure are models defined in Australian (Velth and Arndt, 2011) and UK guidelines (HA, 2007) which suggest indirect control of speed by checking vehicle-path radius at the entrance of roundabout without direct estimation of the speed at that point.

First Croatian guidelines for roundabouts design were published in 2002 (Dadić et al., 2001) and presently are actual those from 2014 (HC, 2014). Geometric elements as well as the way consistency of roundabout designed is estimated by the control of path-alignment, sight distance conditions and check-up of operating speed through roundabout which are based on those defined in Dutch, Slovenian and Serbian guidelines and different from procedures in USA, UK and Australian regulation for roundabouts.

Pilko et al. (2014) in their paper presented the results of research on the 4 roundabouts in Croatia, discrepancy between the measured speed V_{85} and those calculated according to the FHWA model was evident (from -46% to $+13\%$).

To establish reliability of application of both ordinarily used models for speed control at roundabouts, at those designed and constructed in Croatia, field research was performed and operating speeds were measured on selected roundabouts. First results showed certain unreliability of existing models in Croatian conditions for both speed control models. To establish path elements which can lead to better understanding of vehicle movement through roundabout and more accurate speed calculation, further field research was carried out. The main goal of this research was to define maximum speed vehicle path elements. During field research, maximum speed on vehicle theoretical path defined by FHWA model (FHWA, 2000) as well as maximum speed on the vehicle optional path was established and then compared.

The aim of this paper is to present results of preliminary measurements of the speed at selected roundabouts and analysis of results and comparison of measured and calculated speeds. The paper presents an analysis of the path elements (max speed path) of the vehicles passing through the roundabout suggested in the literature and experimental verification of the same. The goal of this research is to verify existing models which define movement paths and to experimentally determine the vehicle path through the roundabout as a first step in development of a model of the operating speed through the roundabouts.

2. Overview of existing models for maximum-speed path definition

When verifying the operational speed through the roundabout, the design vehicle to check the operational speed according to all analyzed guidelines is a passenger car which in average achieves maximal speed when passing through the

roundabout. Below is an overview of assessment methods of the maximum speed and the formation of fastest vehicle paths adopted in two main groups of guidelines for roundabouts that treat this problem in the same or similar way:

- CROW model: Dutch, Slovenian, Serbian and Croatian guidelines.
- FHWA model: American guidelines.

In Australian and British guidelines the assessment is based on meeting the requirements of the appropriate entrance path radius on the straight vehicle path through the roundabout. These models were not analyzed in this study.

2.1. Model based on the correlation of basic design elements of the intersection – CROW model

Model based on the correlation of basic design elements of the roundabout is originally defined in Dutch guidelines (CROW, 1998) and taken into Slovenian (MPRS, 2011), Serbian (PS, 2012) and Croatian guidelines for roundabouts (HC, 2014).

The acceptable operational speed through the roundabout, according to these guidelines, depends on the size of the roundabout defined by the size of the outer radius and are in range from 25 to 40 km/h in Croatian (HC, 2014) and up to 30–35 km/h in Dutch (CROW, 1998; DMT, 2009), Slovenian (MPRS, 2011) and Serbian's guidelines (PS, 2012).

The process of verification of operating speed through the roundabout implies verification of the vehicle path and on the basis of defined path radius at the roundabout, and the calculation of the vehicle speed through the roundabout. The first step in the process of verification of the operating speed is to determine the radius of the vehicle path through the roundabout according to Eq. (1), shown graphically in Fig. 1.

$$R = \left\{ (0.25L)^2 + [0.5(U + 2)]^2 \right\} / (U + 2) \quad (1)$$

where R is the radius of the vehicle path through the roundabout (m), L is the tangent distance between the beginning of the entrance (curb) radius and end of the exit (curb) radius (m), U is the distance between tangent (from the beginning of the entrance radius to the end of the exit radius) and the edge of the central island (m).

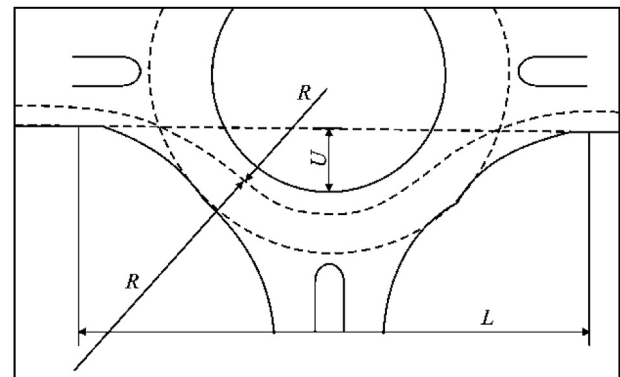

Fig. 1 – The curvature of the vehicle path through a roundabout (CROW, 1998).

The effect of the increasing of parameter U (by increasing central island radius) to reduction of speed is greater than the impact of the parameter L , which represents a decrease/change of the value of entrance and exit radius. To achieve the same influence, the parameter L should be reduced more than the parameter U should be increased. The approximate correlation factor between these sizes is 8 (MPRS, 2011; PS, 2012). According to the Dutch, Serbian, and Slovenian guidelines the acceptable solutions are considered to be those in which the value of the radius of the vehicle path is between 22 and 23 m (CROW, 1998; MPRS, 2011; PS, 2012).

After determining the radius of the vehicle path, using Eq. (2) the operating vehicle speed through the roundabout is determined as follow

$$V = 7.4\sqrt{R} \quad (2)$$

where V is the operating vehicle speed through the roundabout (km/h), R is the radius of the vehicle path through a roundabout (m).

2.2. Model based on the formula for speed calculation in the horizontal curve – FHWA model

The model based on the formula for calculation of the movement speed in the horizontal curve is defined by the AASHTO publication “A Policy on Geometric Design of Highways and Streets” (AASHTO, 2001). Recommended entry operating speed for single-lane roundabout according to the American guidelines (FHWA, 2000) is 30 km/h to 40 km/h.

The process of the operating speed determination, according to these guidelines, requires drawing of the vehicle path through a roundabout for all allowed directions of movement (Fig. 2), although the assumption that the operating speed when turning left, due to the circulation around a central island, is the lowest and the greatest operating speed is most often on the vehicle path that goes straight through the roundabout, which is the flattest (Fig. 3).

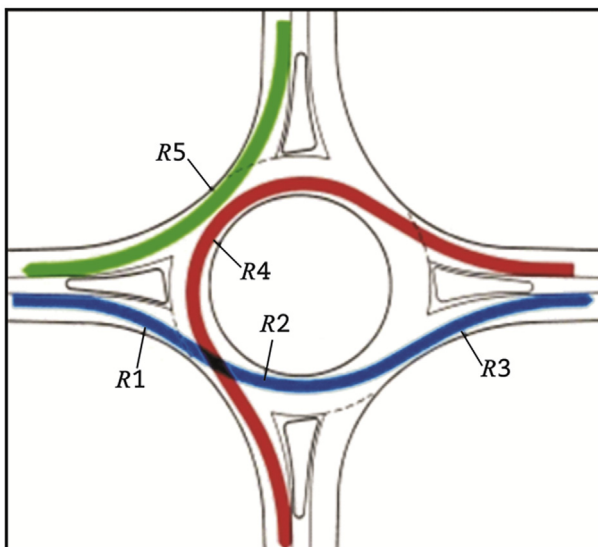

Fig. 2 – Vehicle path radii (FHWA, 2000).

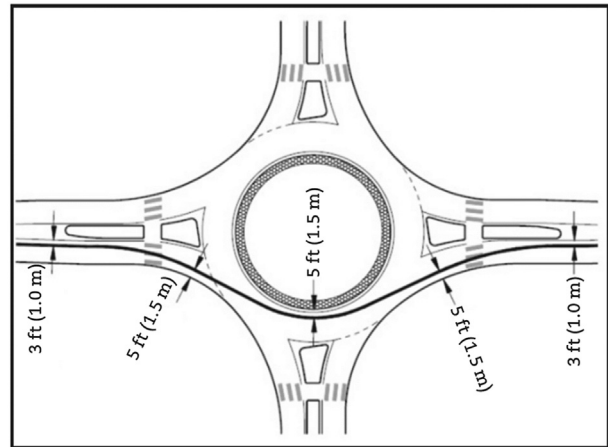

Fig. 3 – Straight through vehicle path (FHWA, 2000).

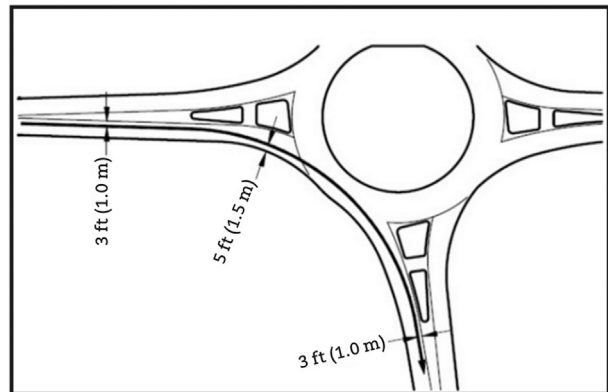

Fig. 4 – Critical right-turn movement (FHWA, 2000).

Exceptions may occur in specially designed roundabouts (for example when the angle between intersection approaches is greater than 90°) where the right-turning vehicle path can result with the highest operating speed (Fig. 4).

In case of vehicle passing straight through the roundabout, it is necessary to construct 3 radii of the path ($R1$, $R2$ and $R3$ of Fig. 2). The radii $R1$, $R2$ and $R3$ represent the lowest radii at the entrance, in the roundabout and at the exit from the roundabout. In the case of the left turn of the vehicle, only radius $R4$ is determined – the smallest radius of the left-turning vehicle path while in case of right-turning of the vehicle the radius $R5$ is determined (the radius of the right-turning vehicle path) (FHWA, 2000).

During the construction of the vehicle path it is assumed that the vehicle width is 2 m and minimum safety distance is 0–0.5 m from vehicles to raised curbs, marked lines or the middle of the roadway/pavement. Considering the aforementioned, during the construction of the vehicle path, the distance of 1.5 m from the central islands and curbs at the entrance and exit is adopted, and 1.0 m from the marked line on the pavement is adopted as well. The construction of the vehicle path through the roundabout according to the American guidelines is based on the assumption that a straight vehicle path consists of three consecutive radii, and one right vehicle path (Fig. 2). The Guidelines state that the entry radius

R1, in a straight vehicle path, is a deflection measure imposed at vehicle just before its entrance into the roundabout, and thus it is a possible measure of the achieved security level at the entrance of the intersection.

Fig. 3 shows the method of determining of the value of the radius R1. Construction of the path itself, according to FHWA, 2000 should be initiated at least 50 m before the stop line at the entrance of the roundabout, using the aforementioned protective widths. The guidelines stipulate that the length of the arc radius R_1 should not be smaller than 25 m (Fig. 5).

Once the radii of the vehicle path are determined it is possible to calculate the expected operating speed of vehicles on the path according to Eq. (3). Recommendation for these values is given in the Guidelines (FHWA, 2000). According to Eq. (3), vehicle speed other than on the curvature radius, depends on the value of cross fall and the friction coefficient between the rubber wheels and road surface.

$$V = \sqrt{127R(e + f_t)} \quad (3)$$

where e is the cross fall of the pavement (m/m), f_t is the friction coefficient between the wheel and pavement.

3. Preliminary operational speed measurements on selected roundabouts

Based on previous analyses of existing models and recommendations for calculation of the operational speed in the roundabouts, the need arose for reliability checks of these models designed on roundabouts according to design elements defined in the Croatian national guidelines. A preliminary testing of the operating speeds was conducted on three four leg single-lane roundabouts in Croatia. The aim of this study was to determine the operational speed of vehicles at selected positions in the roundabout: at the entrance of the roundabout, in the middle of the roundabout and at the exit from the roundabout, in order to analyze and compare them with the speeds calculated according to existing models of the speed calculations at the roundabouts.

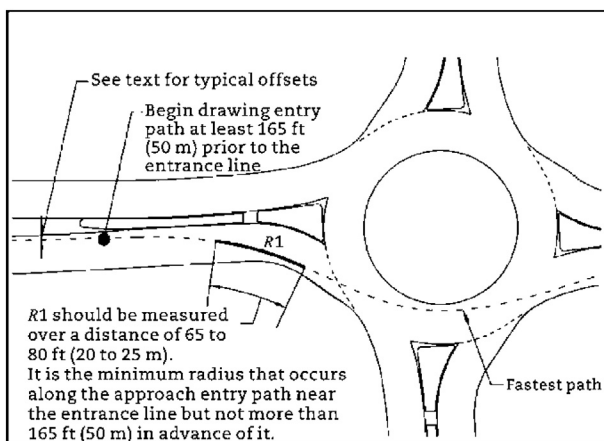

Fig. 5 – Determining of the radius R1 according to Rodegerdts et al. (2010).

3.1. Preliminary site measurements

The first phase of field testing included determining the speeds on three selected roundabouts (Fig. 6). The selected roundabouts can be characterized as medium-sized roundabouts, with external radius of 18, 22.5 and 24.5 m, of different geometric elements, designed according to Croatian Guidelines. Selected roundabouts have basic traffic conditions in common: at intersections there is no pedestrian and bicycle traffic or they can be disregarded. They have a defined main direction and the main direction is straight through the roundabout.

Field testing was carried out separately for each intersection, during one working day but not in peak hours, so that the recordings of the traffic flows would include the real vehicle speeds in unobstructed traffic conditions. Weather conditions at the intersection were stable, without precipitation or other weather conditions that can affect the vehicle speed. Five traffic counters “Datacollect SDRtraffic +” were used for speed measurements. Counters work on the principle of doppler radar, effect of which is based on the change in frequency of the reflected sound wave. The counters were placed in such a manner that the speed profile in the area of the intersection can be obtained from results. Speed was recorded: at about 60 m before the entrance, at the entrance of the roundabout, at the middle of the roundabout, at the exit from the roundabout and approximately 60 m after the roundabout. Speed was measured on the main direction: 1-4 and 4-1 on roundabout A and 1-3 and 3-1 on roundabouts B and C.

3.2. Analyses of the preliminary measurement results

Analysis of the results included determining of the speed V_{85} of the vehicles at the entrance of the roundabout, in the middle of the roundabout and at the exit of the roundabout. Speeds measured before and after the intersection are excluded from this analysis. The analysis included vehicles which passed straight through the roundabout in a free flow without interference or conflicts with other vehicles.

The measured speed V_{85} shows that on the analyzed intersections the achieved operational speeds are in range prescribed by the guidelines analyzed in this paper. At the most sensitive point of the roundabout, at the entrance, the speeds do not exceed 40 km/h. Based on 5 of 6 analyzed straight directions, comparison of speeds show that the measured speeds are higher at the entrance than at the exit. Due to the maximum curvature of the vehicle path, the expected lowest speeds are recorded in the middle of the roundabout (on 5 of 6 directions). Typically, lowest measured vehicle speeds at the exit of the roundabout can be considered unexpected because at the analyzed intersections there were no pedestrians and/or cyclists who would directly or indirectly have an impact on the need to reduce the speed at the exit from the roundabout.

Subsequently the measured speed V_{85} was compared with those calculated according to the aforementioned two models: Model 1 (CROW model) that is based on the verification of defined geometric parameters of the roundabout and Model 2 (FHWA model) based on the well-known formula for the speed of the horizontal curve as explained in more detail in Section 2 of this paper. The results and the comparison of

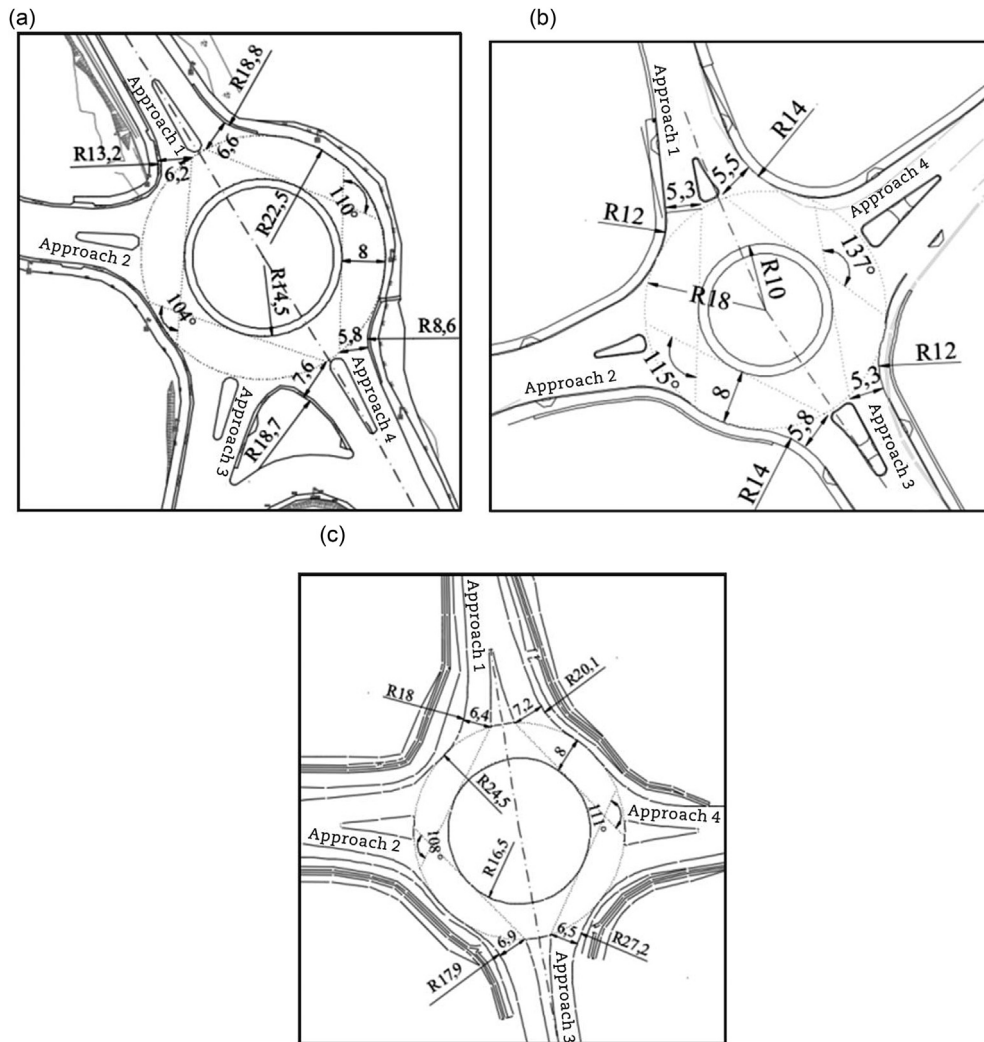

Fig. 6 – Roundabouts used for maximum speed path analyses. (a) Roundabout A. (b) Roundabout B. (c) Roundabout C.

Table 1 – Comparison of measured and calculated speeds at the roundabout.

Roundabout	Direction	Entrance			Middle			Exit		
		Measured V_{85}	FHWA	CROW	Measured V_{85}	FHWA	CROW	Measured V_{85}	FHWA	CROW
A	1-4	32	39	37	25	28	37	25	38	37
	4-1	19.9	24.2	23.0	15.5	17.4	23.0	15.5	23.6	23.0
B	1-3	30	38	33	28	29	33	29	43	33
	3-1	18.6	23.6	20.5	17.4	18.0	20.5	18.0	26.7	20.5
C	1-3	39	69	*	21	28	*	24	40	*
	3-1	24.2	42.9	*	13.0	17.4	*	14.9	24.8	*
B	1-3	37	52	48	37	35	48	30	36	48
	3-1	23.0	32.3	29.8	23.0	21.7	29.8	18.6	22.4	29.8
C	1-3	37	44	39	25	31	39	31	47	39
	3-1	23.0	27.3	24.2	15.5	19.3	24.2	19.3	29.2	24.2
C	1-3	25	44	41	23	31	41	44	49	41
	3-1	15.5	27.3	25.5	14.3	19.3	25.5	27.3	30.4	27.3

Note: “*” Speed can't be calculated because the angle between approaches the model is not applicable.

the measured speed V_{85} with speeds calculated using the aforementioned models, for 3 selected roundabouts (A, B and C, or 6 straight paths through the intersection) are shown in Table 1.

The measured speeds at all roundabouts are lower than the speeds obtained by calculation according to the aforementioned models for calculation of speeds. The biggest discrepancies between predicted and measured speed are at the

entrance and exit of the roundabout and some minor deviations between predicted and measured speed occurred in the middle of the roundabout. Model 2, according to the FHWA (2000), gives the value of the operational speeds of 19%–40% greater than the measured speeds, while the speeds calculated by the Model 1 (CROW, 1998) are 5%–30% higher than measured.

Because of the range of differences, it was not possible to determine a clear correlation of the measurement results and existing models. Since all analyzed cases excluded the influence of pedestrian and bicycle traffic as well as possible interference during the transit of vehicles through the intersection it can be concluded that the measured speeds are largely a result of the applied geometric elements, i.e., the curvature of actually vehicle paths while passing straight through the roundabout. With the dispersion of results and a too small sample the correlation between speed and design elements which define the movement path could not be established and further detailed field testing of the vehicle path through the roundabout were conducted.

4. Maximum speed path analyses

Furthermore, the research is focused on defining the elements with the help of which would be able to accurately determine the path on which vehicles achieve a maximum speed at the entrance, when passing through the roundabout and at its exit. Based on the analysis of the used models of speed verification, for further analysis, the Model 2 – FHWA model was selected, which is based on speed verification in a curve, suggested according to FHWA (2000). Model 1 – CROW model based on the geometry according to (CROW, 1998) is shown to be significantly influenced by geometric elements prescribed according to CROW (1998) which do not apply in Croatia and

neighboring countries, and it was not possible to verify it experimentally.

4.1. Site measurements methodology

To verify the maximum speed path of selected FHWA model, roundabout A was chosen (Fig. 7), which was already analyzed in preliminary tests, and also another roundabout with similar geometric characteristics, roundabout D (Fig. 8). Four straight directions through the roundabout were analyzed, two on each roundabout (blue and red lines of Figs. 7 and 8).

Using AutoCAD software, on the geodetic situations of roundabouts, theoretical paths of the vehicle were designed according to FHWA (2000) with all the suggested elements and protective distances prescribed by these guidelines (Figs. 7(a) and 8(a)). For each constructed theoretical path, radii at the entrance, in the middle and at the exit of the roundabout were measured and speeds were calculated using FHWA model (Model 2), on 3 positions for each of 4 straight directions on selected roundabouts.

In the next step, each of the three circular arcs of the theoretical path constructed on the geodetic situations of roundabouts, is transferred to the pavement of the intersection by using 9 points (stakeout points) and thus the theoretical path was actually “drawn/marked” on the pavement (Figs. 7(b) and 8(b)).

Applied methodology for measuring the speed of vehicles was the one which sought to counteract the negative effect which traffic counter (like other similar spot speed methodologies) has on drivers (Misaghi and Hassan, 2005). Experimental testing included 50 vehicle passes following theoretical paths marked on the pavement for each roundabout. The same passenger car was used, and three drivers were alternated (2 male and 1 female). Each of 50

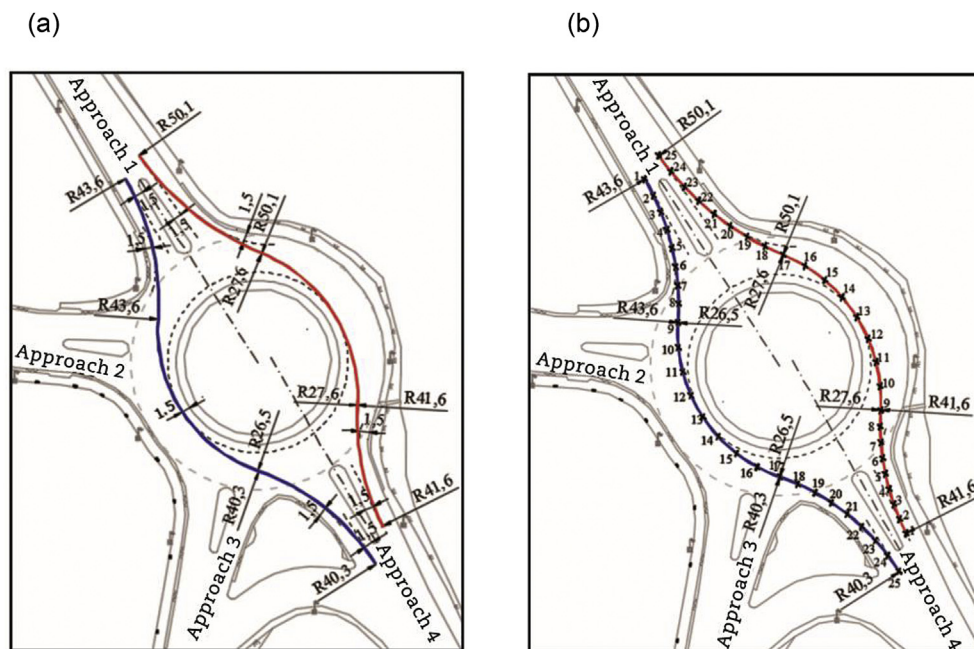

Fig. 7 – Theoretical path according to FHWA model and stakeout points for roundabout A. (a) Theoretical path. (b) Stakeout points.

of the roundabout (V_{mid}) and at the exit (V_{exit}) were determined, for each pass on theoretical-marked and optional path. Statistical analysis was conducted for the collected data which included the determination of the average values (μ), standard deviation (SD), minimum and maximum values of speed and range of results. The paper presents only the average calculated speeds.

Each pass of a vehicle, i.e., the path composed of a series of points recorded by GNSS device, was approximated by circular arcs, at the entrance, in the middle of the roundabout and at the exit, and the value of the radius of arcs were read. Results of measured speeds achieved by driving on theoretical-marked path and their comparison with speeds calculated using FHWA model are shown in Table 2, for each of two straight directions on roundabouts A and D.

From Table 2, it is evident that there is a difference between the speed at the entrance, middle and exit, calculated according to the FHWA model and the average speeds for driving on a theoretical path. In order to determine whether the difference between these speeds is significant the parametric t-test for one sample was used (Sošić, 2006). The null hypothesis H_0 was tested, which claims that the average mean value of speed for driving on a theoretical path is equal to a certain value (in this case, it is equal to the speed at the entrance, middle and at exit calculated according to the FHWA model).

The results of t-test for significance level $\alpha = 0.05$ are given in Table 3. All p-values greater than 0.05 indicate the

acceptance of the null hypothesis. In the case of the roundabout A, the test shows that there is no difference between the average speed for driving on a theoretical path and the speed determined by the FHWA model in case of exit from the intersection (direction 1-4), at the entrance and in the middle (direction 4-1). In the remaining cases (the speed at the entrance and in the middle of the intersection for the direction 1-4 and speed at the exit from the intersection for direction 4-1), the null hypothesis is rejected and it can be concluded that the difference of those speeds is statistically significant and not the result of random occurrences. In case of the roundabout D, it is visible that in all cases except for the speed at the entrance of the intersection for direction 3-1, for which the result is on the border value, the null hypothesis is rejected and it can be concluded that the above average speed at the theoretical path is statistically different from the speeds calculated by the FHWA model with a significance level $\alpha = 0.05$.

Since we observed a deviation of the speeds determined from the data obtained from the GNSS device for driving on a theoretical path from those calculated by the FHWA model for both intersections. The next step in these tests was to determine the speed from the data obtained by the GNSS device for driving on an optional path of vehicles (Table 4).

In this case as well, the measurement was conducted by driving through the same selected roundabouts (A and D), in each of two straight directions through the intersection. The implemented methodology was entirely the same as with

Table 2 – Comparison of the results of measurements (for driving on a theoretical path) with speeds calculated using FHWA model.

Roundabout		A						D					
		1-4			4-1			1-3			3-1		
		Entrance	Middle	Exit	Entrance	Middle	Exit	Entrance	Middle	Exit	Entrance	Middle	Exit
FHWA model	Speed (km/h)	39	28	37	38	28	43	39	31	42	40	28	41
	Speed (mph)	24.2	17.4	23.0	23.6	17.4	26.7	24.2	19.3	26.1	24.8	17.4	25.5
	Path radius (m)	43.6	26.5	40.3	41.6	27.6	50.1	43.2	29.7	50.1	43.2	25.6	48.6
For driving on theoretical path	Speed (km/h)	36	30	31	38	29	32	40	30	35	41	31	34
	Speed (mph)	22.4	18.6	19.3	23.6	18.0	19.9	24.8	18.6	21.7	25.5	19.3	21.1
	Path radius (m)	38.4	24.4	42.9	40.8	25.5	46.5	39.9	28.4	51.0	38.8	23.5	45.7

Table 3 – Results of t-test for comparison of average speeds on theoretical path and speeds calculated by the FHWA model.

	Roundabout A, direction 1-4			Roundabout A, direction 4-1			Roundabout D, direction 1-3			Roundabout D, direction 3-1		
	Entrance	Middle	Exit	Entrance	Middle	Exit	Entrance	Middle	Exit	Entrance	Middle	Exit
p-value of t-test	<0.0001	<0.0001	0.3680	0.5010	0.0130	<0.0001	<0.0001	<0.0001	<0.0001	0.0500	<0.0001	<0.0001

Table 4 – Results of speed measurement for driving on an optional path of the selected roundabouts.

	Roundabout A						Roundabout D					
	Direction 1-4			Direction 4-1			Direction 1-3			Direction 3-1		
	Entrance	Middle	Exit	Entrance	Middle	Exit	Entrance	Middle	Exit	Entrance	Middle	Exit
Avg. speed (km/h)	39.273	32.438	34.376	39.886	30.662	34.615	42.026	31.792	36.094	42.300	32.616	34.297
Avg. speed (mph)	24.403	20.156	21.360	24.784	19.052	21.508	26.113	19.754	22.428	26.284	20.266	21.311
Stand. dev.	2.490	1.934	1.939	1.440	1.502	1.534	1.888	1.414	1.855	1.587	1.691	1.830

the previously analyzed measurements. Table 4 shows the results obtained by speed measuring on an optional path. It turns out that even in this case the speeds at the entrances of the roundabout are the greatest, while expectedly, speeds are the lowest at the site of the largest deflection, in the middle of the roundabout. Unexpectedly, however, the speeds at the exit from the roundabout are lower than

those at the entrance. The speeds achieved by driving on an optional path through the roundabout were compared using t-test with speeds calculated by FHWA model. Test results shows that in all cases except in case of entrance to the roundabout A (direction 1-4) the average speed for driving on an optional path was statistically different from the speeds calculated by the FHWA model.

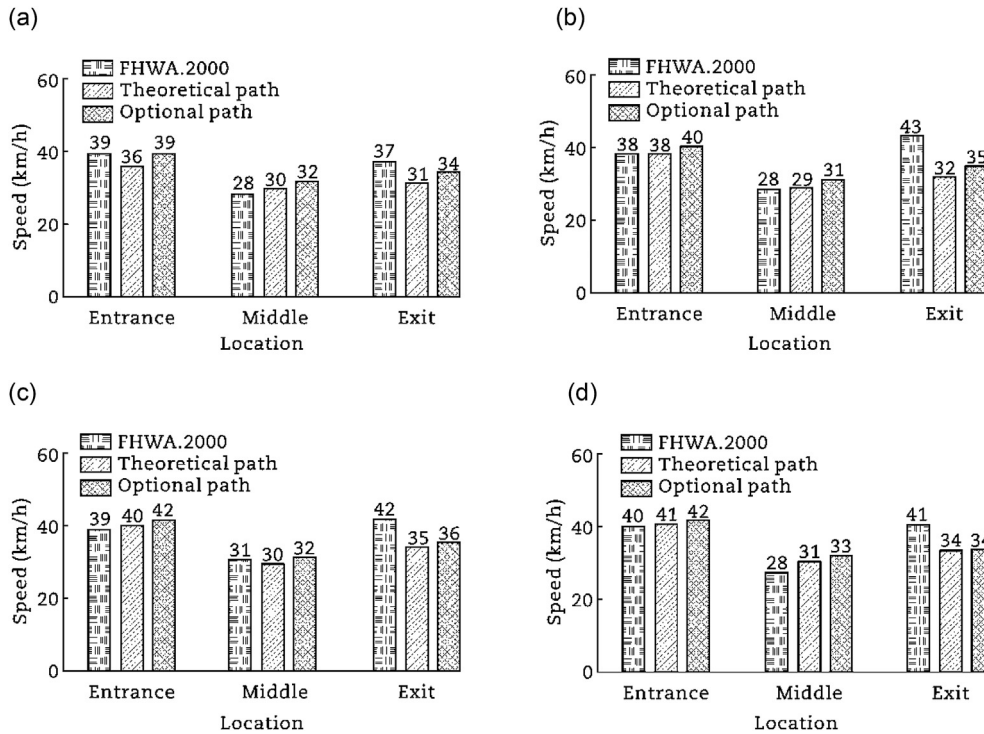

Fig. 10 – Comparison of speeds according to the FHWA model, and speeds measured on the optional and theoretical paths. (a) Roundabout A: direction 1-4. (b) Roundabout A: direction 4-1. (c) Roundabout D: direction 1-3. (d) Roundabout D: direction 3-1.



Fig. 11 – Theoretical and optional paths on roundabout A. (a) Elements of optional path. (b) Comparison of theoretical and optional paths.

Table 5 – Average values of optional path elements at analyzed roundabouts.

Roundabout	Direction	Entry path radius R1 (m)	Length of entry path radius L1 (m)	Path distance from raised curbs at the entrance X1 (m)	Middle path radius R2 (m)	Length of middle path radius L2 (m)	Path distance from central island X2 (m)	Exit path radius R3 (m)	Length of exit path radius L3 (m)	Path distance from raised curbs at the exit X3 (m)
A	1-4	42.9	18.5	1.5	23.3	20.9	0.5	49.9	20.2	1.8
	4-1	55.0	19.0	1.2	23.5	20.2	0.4	56.6	20.8	2.0
B	1-3	46.0	19.2	1.7	25.0	21.8	0.9	55.8	19.7	1.6
	3-1	47.7	21.6	1.4	21.8	23.0	1.0	52.2	20.1	1.3
Recommended values (FHWA, 2000)		–	20–25	1.5	–	–	1.5	–	–	1.5

4.3. Comparison of the results with existing models and guidelines for roundabout design

Results of speeds obtained by measurement on theoretically defined and optional path are now compared with speeds that have been calculated on the basis of FHWA model (FHWA, 2000). Results show that by using FHWA model calculated speeds in the middle of the roundabout are lower than those measured at the field, and speeds at the exit significantly higher than those measured at the field (Fig. 10) (FHWA, 2000).

Comparison of speeds calculated by FHWA model and those achieved on a theoretical path (Tables 2 and 3) showed that the speeds are statistically different, even for the case when driving was carried out in controlled conditions. Comparison of speeds calculated by FHWA model and speeds achieved during driving on the optional path also showed a statistically significant difference. Overall conclusion is that model offered in FHWA (2000) does not suit conditions on roundabouts designed on the basis of Croatian and group of similar guidelines (MPRS, 2011; PS, 2012). We can assume that it is because of different geometric elements proposed in different guidelines but also because of the driving culture and tradition in implementing roundabouts.

The next step was to examine the elements of the speed path that was tracked with the GNSS device during test-driving conducted on optional path (Fig. 11). The geometric elements were established from altogether 200 drives on 4 straight paths on roundabouts A and D and then compared. They were also compared with values proposed for formation of maximum speed path in FHWA model (FHWA, 2000).

Fig. 11(a) shows the method of approximating the elements of optional paths and Fig. 11(b) comparison of recorded optional and theoretical paths on the same intersection, same direction.

The measured average length of the entry path radius on an optional path is in 3 of 4 cases smaller from the one recommended by the USA guidelines. USA guidelines recommend the formation of path by adopting a detachment 1.5 m away from the curb at the entrance of the roundabout and at the exit. The experimentally determined average detachment at the entrance is of 1.45 m, 1.675 m at the exit and 0.7 m at the middle. While the difference between the entrance and the exit can be considered acceptable, deviation within $\pm 12\%$ difference in the established and recommended average value of detachment in the middle of the roundabout is significant. Entrance and exit path radii are not commented because they

happened to be very different. The average values of optional path elements at analyzed roundabouts can be seen in Table 5.

5. Conclusions

Estimating speed as precisely as possible is an iterative process of roundabout design and it is very important to assure its proper traffic safety. There are two mainly used models for establishing operational speed at roundabouts on the basis of its design: the model called in this paper FHWA model based on the definition of maximum speed path and CROW model based on correlation of basic design elements of the intersection.

Field study presented in this paper performed on chosen roundabouts in Croatia shows that neither of two models has sufficient accuracy and be applied to roundabouts in Croatia. Further field measurements were performed in order to establish which of the elements in the procedure have to be corrected. Speed was measured by driving on theoretically defined speed path marked on the pavement and by driving on an optional path through roundabout. Measured speeds were compared with speeds calculated by using the model proposed in USA guidelines.

The results show the following:

- Existing FHWA model for calculating the speed recommended by the US guidelines is not entirely applicable to roundabouts in Croatia (and countries with similar design settings) because it provides speeds that substantially differ from those measured. The maximum deviation between the measured and calculated speeds are observed at the exit of the roundabout;
- Speeds at the entrance of the roundabout vary the most regardless of the measurement method, as indicated by the highest standard deviation of these values. Since the entrance of the roundabout, in terms of traffic safety, represents the most problematic section of the roundabout, it is necessary to further analyze the influences that certain geometric, traffic and environmental conditions have on this speed;
- In this paper, we applied two methods of experimental gathering of speeds: the direct measurement of the speed of vehicles in the roundabout collected by using measuring equipment at the intersection (traffic counters) and with targeted repeated drives under controlled circumstances

(higher number of passes, same vehicle, more drivers). Comparison of two applied methods of actual speed determination at the roundabout shows that the more relevant information are obtained by targeted testing, i.e., by driving through the intersection while recording the path with precise GNSS device because in this manner more uniform speeds are gained with significantly less waste of results.

- Experimentally determined elements of the vehicle path through the roundabout, as it turned out, do not correspond to those recommended by the USA guidelines. Recommended distance for constructing vehicle path, which represents the basis for determining operational speed in a roundabout, has shown considerable deviation in relation to values of experimentally determined measurements. This particularly applies to distance which vehicles have in the middle of the roundabout where, as it is shown, the actual paths move significantly closer to the central island, which makes the entire path of the vehicle more stretched (with less deflection) from the one predicted by the US guidelines.
- More precisely determined elements of the vehicle path and of the measured speed represent the basis for possible defining of an operating speeds model.
- Provided research methodology may also be applied in the case of double-lane or multilane roundabouts, which would enable the determination of the vehicle path at such intersections, in which the choice of optional path is significantly less limited by geometrical elements of the intersection itself.

REFERENCES

- Al-Ohmari, B.H., Ghuzlan, K.A., Al-Helo, L.B., 2014. Modeling through traffic speed at roundabouts along urban and suburban street arterials. *Journal of the Transportation Research Forum* 53 (2), 7–19.
- Ambros, J., Novak, J., Borsos, A., et al., 2016. Central European comparative study on traffic safety on roundabouts. In: 6th Transport Research Arena, Warsaw, 2016.
- American Association of State Highway and Transportation Officials (AASHTO), 2001. A Policy on Geometric Design of Highways and Streets. AASHTO, Washington DC.
- Bassani, M., Sacchi, E., 2012. Calibration to local conditions of geometry-based operating speed models for urban arterials and collectors. *Procedia–Social and Behavioral Sciences* 53 (3), 822–832.
- Bassani, M., Dalmazzo, D., Marinelli, G., et al., 2014. The effect of road geometrics and traffic regulations on driver-preferred speeds in northern Italy. An exploratory analyses. *Transportation Research Part F: Traffic Psychology and Behavior* 25, 11–26.
- Chen, Y., Persaud, B., Sacchi, E., et al., 2013. Investigation of models for relating roundabouts safety to predicted speed. *Accidents Analysis and Prevention* 50, 196–203.
- CROW, 1998. Eenheid in Rotondes. CROW Publication, Ede.
- Dadić, I., Tollazzi, T., Legac, I., et al., 2001. Smjernice za Projektiranje i Opremanje Raskrižja Kružnog Oblika–rotora. Institut Prometa i Veza, Zagreb.
- Dutch Ministry of Transport (DMT), Public Works and Water Management, 2009. Roundabouts–Application and Design: A Practical Manual, Partners for Roads. Dutch Ministry of Transport, Public Works and Water Management, Haren.
- Easa, S., Mehmood, A., 2004. Optimizing geometric design of single-lane roundabout: consistency analysis. *Canadian Journal of Civil Engineering* 31 (6), 1024–1038.
- Elvik, R., 2003. Effects on road safety of converting intersections to roundabouts: a review of evidence from non U.S. studies. *Transportation Research Record* 1847, 1–10.
- Federal Highway Administration (FHWA), 2000. Roundabouts: An Informational Guide Report. FHWA-RD-00-067. FHWA, Washington DC.
- Highways Agency (HA), 2007. Geometric Design of Roundabouts. Design Manual of Roads and Bridges. Available at: <http://www.standardsforhighways.co.uk/ha/standards/dmrb/vol6/section2/td1607.pdf>. (Accessed 6 January 2017).
- Hrvatske ceste d.o.o. Zagreb (HC), 2014. Smjernice za Projektiranje Kružnih Raskrižja na Državnim Cestama. Izrađivač. Građevinski fakultet Sveučilišta u Rijeci, Rijeka.
- Jensen, S.U., 2013. Safety effects of converting intersections to roundabouts. *Transportation Research Record* 2389, 22–29.
- Kennedy, J.V., Peirce, J., Summergrill, I., 2005. International comparison of roundabout design guidelines. In: International Symposium on Highway Geometric Design, Chicago, 2005.
- Kim, S., Choi, J., 2013. Safety analysis of roundabout designs based on geometric and speed characteristics. *KSCE Journal of Civil Engineering* 17 (6), 1446–1454.
- Ministarstvo za promet Republika Slovenija (MPRS), 2011. Tehnička specifikacija za javne ceste–Krožna Križišča. MPRS, Ljubljana.
- Misaghi, P., Hassan, Y., 2005. Modeling operating speed and speed differential on two lane rural roads. *Journal of Transportation Engineering* 131 (6), 408–418.
- Montella, A., Turner, S., Chiaradonna, S., et al., 2012. Proposals for improvement of the Italian roundabout geometric design standard. *Procedia–Social and Behavioral Sciences* 53 (3), 189–202.
- Montella, A., Turner, S., Chiaradonna, S., et al., 2013. International overview of roundabout design practices and insights for improvement of the Italian standard. *Canadian Journal of Civil Engineering* 40 (12), 1215–1226.
- Pilko, H., Brčić, D., Šubić, N., 2014. Istraživanje brzine kretanja vozila pri projektiranju kružnih raskrižja. *Građevinar časopis Hrvatskog saveza građevinskih inženjera* 66 (5), 407–416.
- Putevi Srbije (PS), 2012. Priručnik za Projektovanje Puteva u Republici Srbiji. Available at: [http://www.putevi-srbije.rs/pdf/harmonizacija/prirucnik_za_projektovanje_puteva/SRDMS-3-kruzne-raskrnice\(120427-srb-konacni\).pdf](http://www.putevi-srbije.rs/pdf/harmonizacija/prirucnik_za_projektovanje_puteva/SRDMS-3-kruzne-raskrnice(120427-srb-konacni).pdf). (Accessed 6 January 2017).
- Retting, R.A., Persaud, B.N., Garder, P., et al., 2001. Crash and injury reduction following installation of roundabouts in the United States. *American Journal of Public Health* 91 (4), 628–631.
- Rodegerdts, L., Bansen, J., Tiesler, C., et al., 2010. Roundabouts: An Informational Guide, second ed. NCHRP Report 672. TRB, Washington DC.
- Silva, A.B., Santos, S., Vasconcelos, L., et al., 2014. Driver behaviour characterization in roundabout crossings. *Transportation Research Procedia* 3, 80–89.
- Šošić, I., 2006. Primjenjena Statistika. Školska Knjiga, Zagreb.
- Velth, G., Arndt, O., 2011. Guide to Road Design Part 4B: Roundabouts, second ed. Austroads, Sydney.
- Wang, J., Dixon, K., Li, H., et al., 2006. Operating-speed model for low-speed urban tangent streets based on in-vehicle global positioning system data. *Transportation Research Record* 1961, 24–33.



Sanja Šurdonja, PhD, is a postdoctoral associate at the Faculty of Civil Engineering at the University of Rijeka. She received her PhD in 2017 at the Faculty of Civil Engineering, University of Zagreb. Her main research interests are in the field of transportation engineering and urban traffic infrastructure. Currently she participates in teaching courses about road and intersection design, urban transport and traffic safety at all levels of studies.

Her research interests are in design and building roads and highways, road intersection design and road traffic noise modeling and protection.



Vesna Dragčević, PhD, is a full professor and currently head of the Department of Transportation Engineering at the Faculty of Civil Engineering at the University of Zagreb. Since 1990 she has been working at the department of Transportation Engineering, Faculty of Civil Engineering, at the University of Zagreb. She was serving as the dean and vice dean for education at the same faculty. She has published more than eighty papers in the field of transportation engineering.



Aleksandra Deluka-Tibljaš, PhD, is a full professor at the University of Rijeka. She is head of Department for Transportation Engineering at the Faculty of Civil Engineering. Her main research interests are in the field of transportation engineering and urban traffic infrastructure and she teaches different courses regarding road and intersection design, urban transport and traffic safety at all levels of studies.