

Embedment strength and stiffness for large diameter mechanical fastener

Pavković, Krunoslav; Stepinac, Mislav; Čizmar, Dean; Pospiš, Nina

Source / Izvornik: **World Conference on Timber Engineering (WCTE 2023), 2023, 2834 - 2840**

Conference paper / Rad u zborniku

Publication status / Verzija rada: **Published version / Objavljena verzija rada (izdavačev PDF)**

Permanent link / Trajna poveznica: <https://urn.nsk.hr/urn:nbn:hr:237:887495>

Rights / Prava: [In copyright](#) / [Zaštićeno autorskim pravom.](#)

Download date / Datum preuzimanja: **2025-01-07**

Repository / Repozitorij:

[Repository of the Faculty of Civil Engineering,
University of Zagreb](#)



EMBEDMENT STRENGTH AND STIFFNESS FOR LARGE DIAMETER MECHANICAL FASTENER

Krunoslav Pavković¹, Dean Čizmar², Mislav Stepinac³, Nina Pospiš⁴

ABSTRACT: The paper presents a parametric numerical analysis of the mechanical fastener developed for large span truss girder. The joint has already been presented in previous papers as well as the experimental tests made on the prototype of the truss girder with this type of joint. In this paper previously obtained experimental tests were used to calibrate the numerical model for parametric analysis. Numerical models are made in the Abaqus / CAE software package. Hill's and Tsai-Wu yield criteria, defined by UMAT subroutine, were used to model the wood yield criteria. Fasteners 49 mm, 59 mm, 69 mm and 79 mm in diameter and the angle between applied load and the grain 30°, 45°, and 60° were researched and results were carried out. From the results obtained by numerical models, expressions for stiffness and embedment strength were carried out and presented in the paper.

KEYWORDS: truss girder, large diameter, mechanical fastener, parametric analysis, UMAT, stiffness, embedment strength

1 INTRODUCTION

The growing presence of timber structures in the construction of large facilities, such as bridges and multi-storey buildings, requires development of the new joints with improved and increased strength and ductility. Since 80% of all timber structure damage has been noticed in the connections [1], it is necessary to develop new generation of joints that will ensure greater durability and ductility of the structure.

Joints in timber structures are commonly made with screws, dowels, and nails or dowel-type fasteners. Extensive research has been conducted on embedment strength parallel to the grain, with several proposed expressions for embedment strength [2–4]; however, most of these are limited to small diameter fasteners. One of the well-known design criteria is defined by Johansen [2], which includes the embedment strength and the appearance of a plastic joint in the fastener. Mentioned criteria are part of the Eurocode 5 (EC5) design fastener protocol and will be only satisfied if the minimum distances between the fastener and the loaded edge of the timber element are respected to ensure ductile behaviour of the joints.

Ensuring the ductility of the large diameter fasteners, often requires increasing the timber element dimensions to unrealistic proportions, which is not economically justified. Another solution is to determine the resistance of the joint to brittle failure mode [5,6] or to locally

reinforce the zone around the fastener [7–10] in order to ensure ductile behaviour.

1.1 JOINT DESIGN AND FAILURE MODES

The design of a joint made with fasteners can be divided into two criteria: the first criterion involves the local design of each individual fastener, and the second criterion involves the design of the entire joint.

The first criterion involves using the limit state method and equations based on K.W. Johansen's work [6] which are already mentioned. According to this theory, joint failure occurs when the pressure in the timber around the fastener reaches the embedment strength or if the plastic moment resistance in the fastener is reached. The mode of failure that will be critical in each joint depends on the thickness of the timber elements, the diameter and material quality of the fastener, the number of share planes, and the boundary conditions of the connection. Figure 1. shows three characteristic failure modes of wood-wood joints with two share planes, and each failure mode can be expressed by the following equation for joint design resistance (R_d):

Mode failure I

$$R_d = f_{h,\alpha,d} \cdot t \cdot d \quad (1)$$

Mode failure II

¹ Krunoslav Pavković, Department for Civil Engineering, University of Applied Sciences, Zagreb, Croatia, e-mail: kpavkovi1@tvz.hr

² Dean Čizmar, Department for Civil Engineering, University of Applied Sciences, Zagreb, Croatia, e-mail: dcizmar@tvz.hr

³ Mislav Stepinac, Faculty of Civil Engineering, University of Zagreb, Croatia, e-mail: mstepinac@grad.hr

⁴ Nina Pospiš, Department for Civil Engineering, University of Applied Sciences, Zagreb, Croatia, student, e-mail: nina.pospis@tvz.hr

$$R_d = f_{h,\alpha,d} \cdot t \cdot d \left[\sqrt{2 + \frac{4M_{y,d}}{f_{h,\alpha,d} \cdot d \cdot t^2}} - 1 \right] \quad (2)$$

Mode failure III

$$R_d = \sqrt{4 \cdot M_{y,d} \cdot f_{h,\alpha,d} \cdot d} \quad (3)$$

Where d is the fastener diameter, t is the thickness of the timber element, $f_{h,\alpha,d}$ is design embedment strength for the load at the angle α regarding to the grain and $M_{y,d}$ is a fastener design plastic moment resistance.

Results obtained using equations (1, 2, and 3) are presented by graphs in Figure 2. and Figure 3. for a joint

with one embedded steel plate in the middle of the timber element. Graphs are displayed as a relation between the width of the timber element and the diameter of the fastener. Two graphs are obtained, one for fasteners up to 30 mm in diameter (Figure 4.) and other for fastener larger than 30mm (Figure 5.) on which above mentioned equation according to Eurocode 5 (EC 5) [11], does not apply. Reason for diameter restriction for which formulas can be used, is shown on diagrams where can be seen that 49 mm diameter fastener has a larger design resistance than 79 mm diameter fastener.

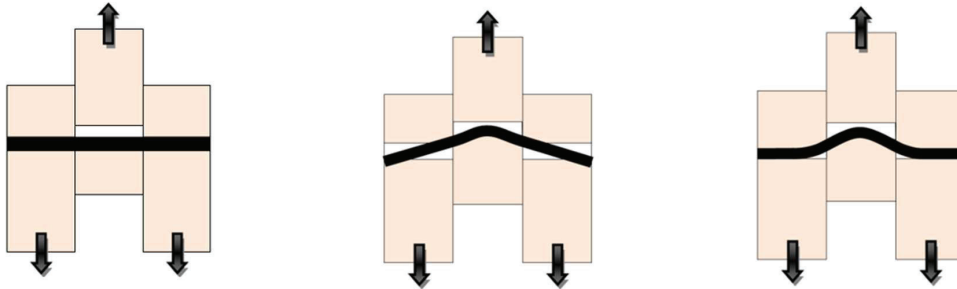

Figure 1. Connection failure modes, from left to right: Mode I, Mode II and Mode III

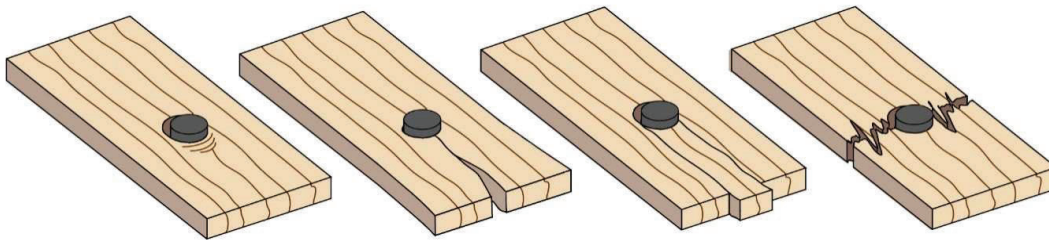

Figure 2. Failure modes in timber joints [9]

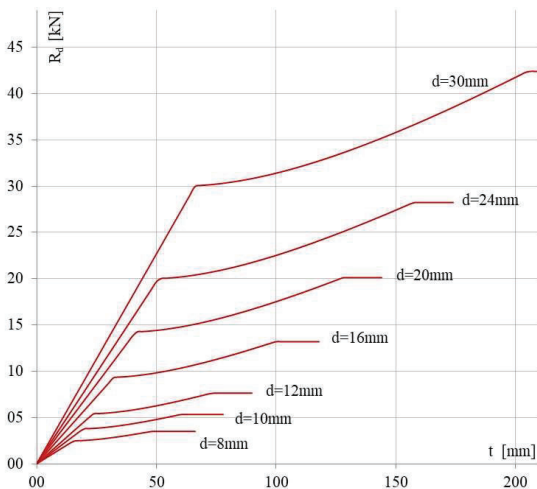

Figure 4. Fastener resistance in relation to the timber width and fastener diameter up to 30mm

The second criterion for the joint design is guidelines for the minimum distances between fasteners and the minimum distance between fasteners and the element edge. These given minimum distances prevent the timber element brittle failure modes and enable the ductile behaviour of the joint. In Figure 2. are presented failure modes including the first ductile mode (left picture) which are mentioned above and can be expressed with Johansen equations and followed by three pictures of brittle failure modes occurred due to: splitting, row shear, block, and plug shear or net tension.

The low deformation capacity of the brittle failure modes does not allow any redistribution of forces and causes an immediate failure of the entire connection and at the end of the entire structure [12].

Minimum distances between connectors that fall within the range of $3d$ to $7d$ usually require a large surface area for the connection. If the minimum distances are applied to dowels type fasteners with a diameter of 30 mm or more, then the problem arises on how to ensure the

minimum distance between the fastener and the element edge which becomes unsolvable without increasing the timber element's dimensions and increasing the wood consumption in the entire structure.

The connection analyzed in this study by using parametric finite element (FE) analysis does not have any problems with brittle failure modes due to its geometry. Since the joint concept within the truss structure ensures ductility and the large diameter tube (fastener) prevents bending of the fastener itself, the only failure mode that needs to be considered and researched is the embedment strength which is expressed by Equation 1.

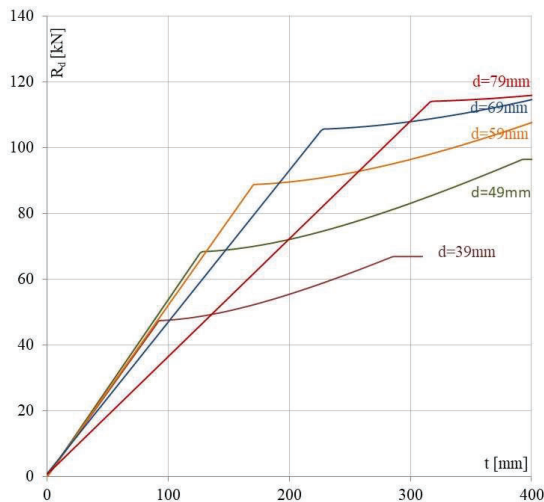

Figure 5. Fastener resistance in relation to the timber width and fastener diameter above 30 mm

2 EXPERIMENTAL REASERCH

Previous experimental studies on the joint with a large diameter mechanical fastener were conducted on 12 small samples, in which the load was applied perpendicular, parallel, and at the 45° angle to the grain. In small samples, failure modes were complex and were mostly caused due to cracking under tensile force perpendicular to the grain which was presented in previous papers [8,9,13].

On four large truss girders experimental research was conducted and presented in paper [14].

The truss girder joint consists of the fastener which is a large diameter pipe mounted in the cord of the truss girder and threaded rods glued in the web elements.

Load transfer from the cord to the web is carried out through high-grade bolts that connects the pipe and the connection nut mounted at the end of the threaded glued-in rod. This type of joint design for truss girders provided very ductile behaviour, unlike small samples where failure modes were mostly brittle due to cracking and block tearing. Measurements conducted during experimental research provided a good basis for calibrating finite element models (FEM) and conducting parametric FE analysis to determine a more suitable

expression for large diameter fastener embedment strength.

The results obtained from experimental testing on the truss girder are shown in the graph in Figure 7 (grey lines) together with the results obtained from the FEM (black line).



Figure 6. Joint monitoring during experimental research on a prototype of truss girder

From the processed experimental results, mechanical characteristic values were determined: maximum force $F_{max} = 333$ kN, yielding force $F_{y,A} = 240.87$ kN, $F_{y,B} = 191.09$ kN, stiffness $K_s = 52$, and ductility $D = 7.02$.

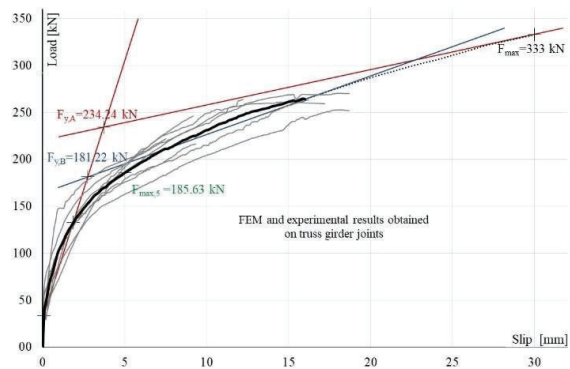

Figure 7. Results obtained from experimental and FEM results

3 PARAMETRIC FINITE ELEMENT MODEL ANALYSIS OF THE JOINT

FEM of the truss girder joint were modelled in Abaqus/CAE software package. C3D4 FE were used for modelling timber and steel elements. Considering that only the local behaviour of the joint is researched, a small part of the timber element (500 mm) around the fastener is modelled. Furthermore, for extra CPU time save, one half of the connection was modelled, as shown in Figure 9.

Within the parametric analysis, a total of 12 FEM were made to obtain results for joint stiffness and embedment strength in relation to the fastener diameter. Parametric numerical analysis was made for fasteners 49 mm, 59 mm,

69 mm, and 79 mm in diameter. Also, for each fastener diameter, three models were made with applied load at the angle of 30°, 45°, and 60° to the grain.

The mechanical properties and yield criteria of the wood were defined in the UMAT subroutine, i.e., Tsai-Wu for the connection zone and Hill for the rest of the timber element, as shown in Figure 8. The UMAT subroutine was described in detail in previous research [8].

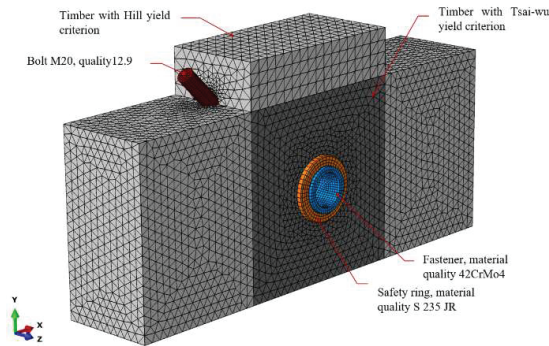

Figure 8. Assigned yield criteria to joint FEM

Absolute stiffness for normal stresses was used to model the contact surfaces, as well as the ability of two surfaces to experience tangential sliding with a friction coefficient. The friction coefficient applied for steel-steel contact was adopted as 0.2, and for wood-steel contact, 0.25.

FEM analyses were carried out using nonlinear analysis with included geometric and material nonlinearity. As in previous research papers [8,14], the Newton method with automatic step control was adopted for force control. The maximum load increment step was limited to 0.25t, with an initial setting of 0.1t, and the load increment was linearly set to 1.0 kN per unit time t.

The loading was modeled as a pressure on the bolt cross section in direction parallel with the axes. The given

pressure on the surface was 4.40567 N/mm², which corresponds to the force of 1000 N on a surface of 226.98 mm². The force increment was linearly guided by the amplitude ratio as a function of time.

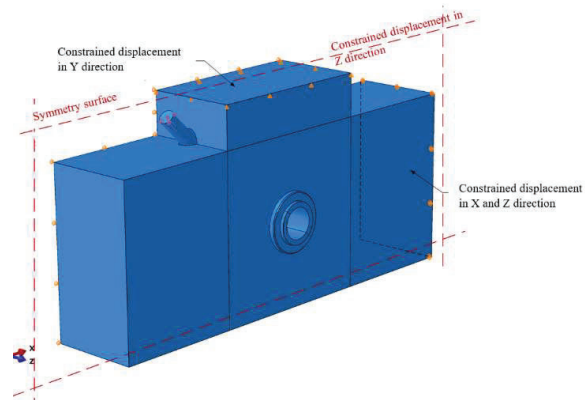

Figure 9. FEM boundary conditions

4 RESULTS AND DISCUSSION

As previously mentioned, a total of 12 FEM were analysed. Results of the joint load-slip behaviour were obtained for each model, and some of the results are shown in Figure 10.

The obtained results were processed according to EN 12512 standard [15], using both recommended methods (Method A and B) for determination of yield force and maximal force of the joint.

According to this standard, the maximum force is determined as the smaller value of the following three conditions: the force at the point of joint failure, 80% of the maximum force reached within a displacement of 30 mm if there is a descending branch in the load-slip curve, and the maximum force at a displacement of 30 mm.

Table 1. Joint characteristic values obtained from load-slip graphs

d [mm]	α [°]	$F_{y,A}$ [kN]	$F_{y,B}$ [kN]	K_s [kN/mm]	D	$F_{max,5}$ [kN]	$f_{h,0}$ [N/mm ²]
49	60	224.41	174.03	38.88	5.64	166	31.37
	45	240.87	191.09	52.00	7.02	195	31.34
	30	276.72	226.93	73.20	8.38	238	31.53
59	60	278.68	205.24	43.87	5.06	187	30.79
	45	300.96	224.94	57.37	6.04	218	30.15
	30	306.53	243.85	83.59	8.49	253	28.31
69	60	292.47	214.42	51.01	5.60	204	30.14
	45	327.58	239.66	63.79	6.17	230	28.21
	30	365.68	261.84	85.74	7.31	266	25.95
79	60	339.66	222.91	56.22	5.29	221	29.91
	45	366.77	247.99	70.92	6.10	244	27.13
	30	424.47	283.70	99.09	6.95	304	26.46

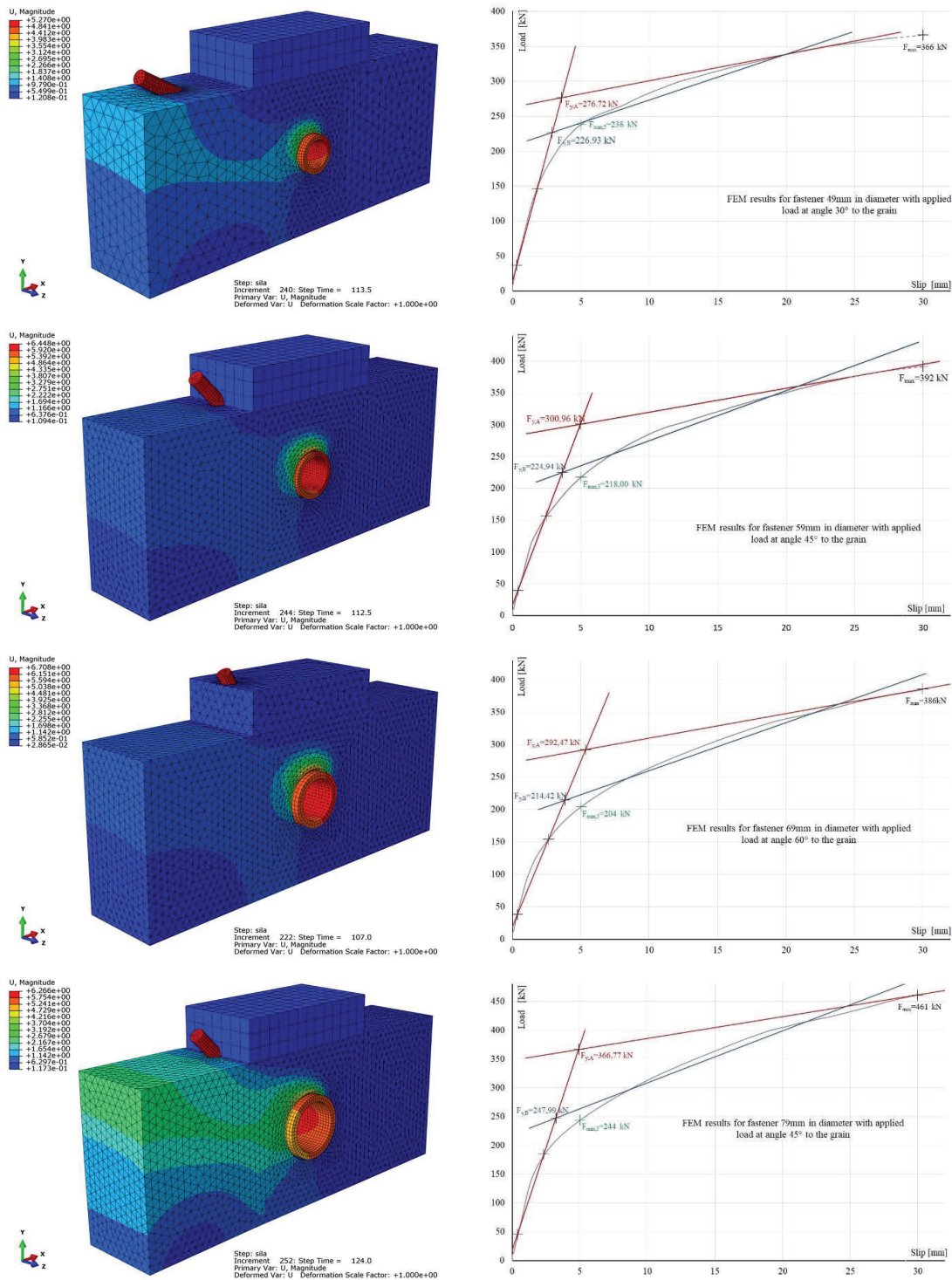

Figure 10. Representation of joint displacement and load-slip graphs obtained by FEM

Yield force according to the method A is determined by the intersection of the two lines; the first line is defined by the values of 10% and 40% of maximal load and the second line is defined by 1/6 inclination of the first line

and maximal load. Method B is carried out by replacing the plastic region of the load-slip diagram from the yield force obtained from method A to the maximum force with a line defined by the least-squares method. The obtained

values from both methods are presented in Table 1. Also, the obtained results are analysed according to EN 12512 for determining the stiffness of the joint, according to the expression:

$$k_s = \frac{0.4F_{max} - 0.1F_{max}}{\delta_{0.4} - \delta_{0.1}} \quad (4)$$

For each FEM fastener embedment strength is determined according to EN 383 [16]. According to this standard, the characteristic embedment strength is obtained by dividing the force which corresponds to a 5 mm slip values ($F_{max,5}$) by the fastener diameter and thickness of the timber element in which the fastener was mounted. These embedment strengths were converted to embedment strength parallel to the grain, and the obtained values are presented in Table 1.

The obtained stiffness results of all 12 FEM were presented in the graph in Figure 11. Using the least-squares method, formulas for the joint stiffness were obtained for each applied load angle separately. Since the graph shows that all three angles of applied load have similar slopes, the main slope was adopted as the unique stiffness equation:

$$K_S = 0,673 \cdot d + 66,71 \cos \alpha - 24,59 \quad (5)$$

The described procedure yielded a unique Equation (5) for determining the stiffness of the researched joint. Since the interception of the results with the y-axis depends on the applied load angle to the grain, and generally on the elastic modulus parallel and perpendicular to the grain, it is necessary to introduce the elastic modulus into the equation. According to the literature [17], the dependence of the three elastic modulus in softwood can be put in a relationship as $E_L:E_R:E_T \approx 20:1.6:1$.

$$K_S = 0,718 \cdot d + (2,713 \cos \alpha - 1) \cdot 2,173 \cdot E_L \quad (6)$$

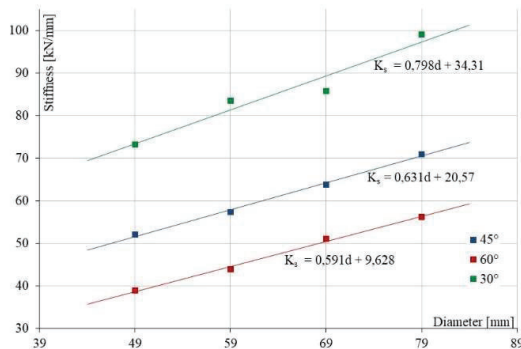

Figure 11. Joint stiffness in relation to the fastener diameter

Taking this into consideration, it can be concluded that introducing one elastic modulus is sufficient for defining unique Equation (6) which covers the type of timber, the

fastener diameter, and the applied load according to the grain.

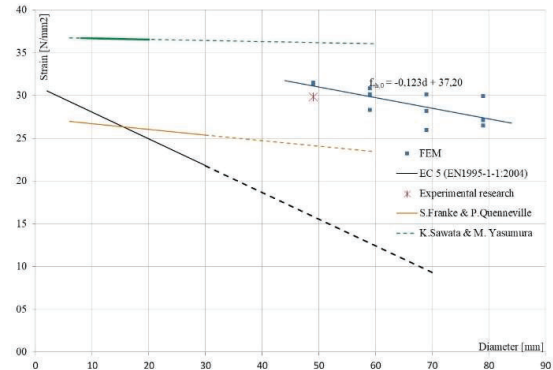

Figure 12. Embedment strength in relation to fastener diameter

The embedment strength for the load parallel to the grain is graphically shown in Figure 12. The results were approximated by a straight line obtained by the method of least squares and the equation of the obtained straight line is given by:

$$f_{h,0} = -0,123 \cdot d + 37,20 \quad (6)$$

From this equation, an expression for the characteristic embedment strength depending on the characteristic density of timber and fastener diameter can be derived as follows:

$$f_{h,0,k} = 0,084(1 - 0,0033d)\rho_k \quad (7)$$

This equation in comparison to the equation for embedment strength in the EC 5 norm gives a more precise embedment strength for large diameter fasteners loaded parallel to the grain.

5 CONCLUSIONS

The connection designed for large span truss girders with large diameter fastener, as presented in this paper, has shown great ductility and resistance. The geometry of the connection ensures failure due to exceeding the embedment strength. Such a designed joint with a large diameter fastener has served as a good basis for determining the expression for the embedment strength. From the parametric analysis, expressions for the embedment strength for fastener larger than 30 mm in diameter were derived. A comparison of the results showed that the proposed expression falls within the limits of previously obtained expressions and has good overlap with the results obtained from experimental research.

The experimental tests and parametric analysis showed that the expression for the embedment strength found in

Eurocode 5 loses accuracy with increasing diameter of the fastener and requires further adjustment through extensive research. Additionally, it is necessary to consider incorporating an expression for embedment strength for fasteners larger than 30 mm in diameter; because this paper, along with several others, has shown that large-diameter fasteners can ensure joints with ductile behavior, high resistance, and stiffness.

REFERENCES

- [1] Santos C, de Jesus A, J. L. Morais J, Louzada J. Quasi-static mechanical behaviour of a double-shear single dowel wood connection. *Constr Build Mater*, 171–82, 2009.
- [2] Johansen KW. Theory of timber connections. *International Association of Bridge and Structural Engineering*; 249–62, 1949.
- [3] Sawata K, Yasumura M. Determination of embedding strength of wood for dowel-type fasteners. *Journal of Wood Science*, 138–146, 2002.
- [4] Franke S, Quenneville P. Bolted and dowelled connections in radiate pine and laminated veneer lumber using the European yield model, 13–28, 2011.
- [5] Jensen J, Girhammar UA, Quenneville P. Brittle failure in timber connections loaded parallel to the grain. *Proceedings of the Institution of Civil Engineers - Structures and Buildings*, 168:760–770, 2015.
- [6] Jockwer R, Fink G, Köhler J. Assessment of the failure behaviour and reliability of timber connections with multiple dowel-type fasteners. *Eng Struct*, 172:76–84, 2018.
- [7] Haller P, Birk T, Offermann P, Cebulla H. Fully fashioned biaxial weft knitted and stitch bonded textile reinforcement for wood connections. *Composites Part B-Engineering - COMPOS PART B-ENG*, 37:278–85, 2006.
- [8] Pavković K, Rajčić V, Haiman M. Large diameter fastener in locally reinforced and non-reinforced timber loaded perpendicular to grain. *Eng Struct*, 74:256–65, 2014.
- [9] Pavković K, Stepinac M, Rajčić V. Brittle failure modes in reinforced and non-reinforced timber joint with large diameter fastener loaded parallel to grain. *Eng Struct*, 222:111104, 2020.
- [10] Pavković K, Rajčić V, Čizmar D. Parametric Analysis of Large Diameter Mechanical Fastener in Reinforced Glulam. *Tehnicki Vjesnik*, 21:843–852, 2014.
- [11] CEN:EN 1995-1-1 :2004. Eurocode 5: Design of timber structures - Part 1-1: General - Common rules and rules for buildings. 2004.
- [12] Jockwer R, Fink G, Köhler J. Assessment of the failure behaviour and reliability of timber connections with multiple dowel-type fasteners. *Eng Struct*, 172:76–84, 2018.
- [13] Pavković K, Čizmar D, Rajčić V. Parametric analysis of large diameter mechanical fastener in reinforced glulam. *Tehnicki Vjesnik*, 21:843–852, 2014;.
- [14] Pavković K, Haiman M, Meštrović M, Rajčić V. Truss girder joint with a large diameter mechanical fastener. *Građevinar*, 65:869–878, 2013.
- [15] EN 12512:2006 Timber Structures - Test Methods - Cyclic Testing of Joints Made with Mechanical Fasteners, Comite Europeen de Normalisation. Brussels. 2006.
- [16] EN 383: 2007 Timber Structures - Test Methods - Determination of embedding strength and foundation values for dowel type fasteners , Comite Europeen de Normalisation. Brussels. 2007.
- [17] Borgin KB, Loedolff GF, Saunders GR. Laminated wood beams reinforced with steel strips. *ASCE Journal of the Structural Division*, 94:1681–1705, 1968.